

ES825-100F/XF/CF Leak Sensors Installation Instructions

Sensor Model

- ES825-100F
- ES825-100XF (Extended Temperature)
- ES825-100CF (Chemical Resistant)

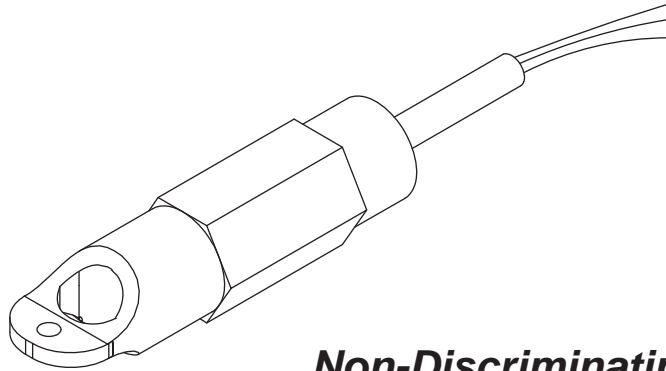

***Non-Discriminating Leak Sensor
w/Supervised Wiring and
Fault Detection, 24 VDC***

**For use with the
following consoles:**

LC2000	TMS2000
TMS3000	
<small>NOTE: ES825-100 SERIES SENSORS ARE NOT COMPATIBLE WITH Wireless DATA ACQUISITION MODULE (WiDAM) USED IN CONJUNCTION WITH WIRELESS CONSOLES. REFER TO THE ES825-300 SERIES.</small>	

© COPYRIGHT 2015 PNEUMERCATOR CO., INC.

TEL: (631) 293-8450
FAX: (631) 293-8533
WEBSITE: www.pneumercator.com
PNEUMERCATOR TECHNICAL SUPPORT
1 (800) 209-7858

PRODUCT DESCRIPTION: Model ES825-100F is a solid-state, electronic leak sensor utilizing electro-optic technology to detect the presence of liquids in secondary containment applications. The "X" version includes all the features of the standard ES825-100F, with operation over an extended temperature range. The "C" version includes all the features of the standard ES825-100F and the "X" version, with the addition of a chemical-resistant sensor body and cable compatible with most acids, alkalines and solvents. The sensors contain no moving parts, are unaffected by vapors, and due to their compact size are ideal for interstitial spaces. When connected with a LC2000 or TMS series controller, they support Pneumercator's FAULT-DETECT supervised wiring technology, which automatically detects sensor or field wiring faults.

APPLICATIONS: Sensors can be installed for leak detection in containment, manway and piping sumps, dry annular space in double-wall tanks, dispenser pans or turbine enclosures. The model selected for each application depends on its compatibility with the stored product.

SPECIFICATIONS:

MODEL NO.	WETTED MATERIALS	OPERATING TEMP.	CABLE	TECHNOLOGY
ES825-100F *	POLYSULFONE, POLYPROPYLENE, PVC & EPOXY	-4°F TO +176°F (-20°C TO +80°C)	22 AWG, 3-CONDUCTOR, PVC JACKET, 25' LONG	ELECTRO-OPTIC, NO MOVING PARTS
ES825-100XF *	POLYSULFONE, POLYPROPYLENE, FEP (TEFLON®) & EPOXY	-40°F TO +176°F (-40°C TO +80°C)	22 AWG, 3-CONDUCTOR, FEP (TEFLON®) JACKET, 20' LONG	
ES825-100CF *	POLYPROPYLENE, PFA, FEP (TEFLON®) & EPOXY			

* Approved for UL Class I, Div 1, Groups C and D hazardous locations when used in conjunction with the TMS series controllers.

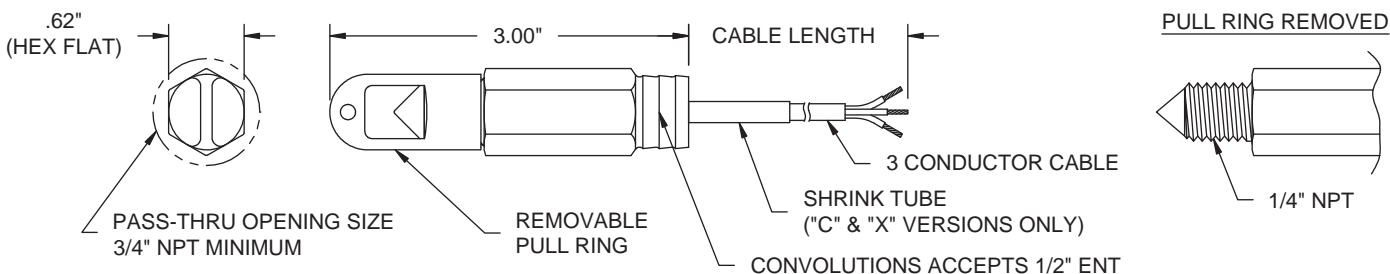

INSTALLATION: Sensor may be suspended by its cable, placed on the containment or sump floor, or thru-wall mounted via a 1/4" FNPT opening. Two methods are available when installing in a dry annular space. The first uses a fish tape and pull string, the second uses a section of 1/2" ENT Flex Conduit attached to the sensor. Pneumercator recommends that sensor should be installed in an area where there is MINIMAL exposure to ambient light.

METHOD 1

1. If tank has an existing pull string, skip steps 2 & 5.
2. Insert Fish Tape through annular space.
3. Attach Pull String to sensor.
4. Tag pull string and cable each 16 feet (for tank diameter up to 10 feet) from sensor.
5. Attach fish tape to pull string.
6. Pull sensor through annulus.
7. Match tag mark on cable and pull string.
8. Sensor now positioned on the bottom centerline of tank.

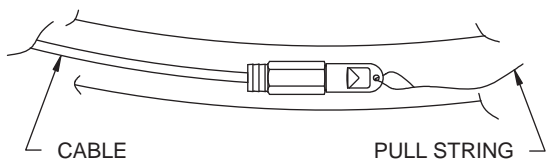

METHOD 2

1. Pull sensor cable through Flex Conduit and insert sensor's back end.
2. Tag conduit at the distance for your tank dia.
3. Feed sensor through annulus.
4. Stop when tag mark is at the top of annulus.
5. Sensor now positioned on the bottom centerline of tank.

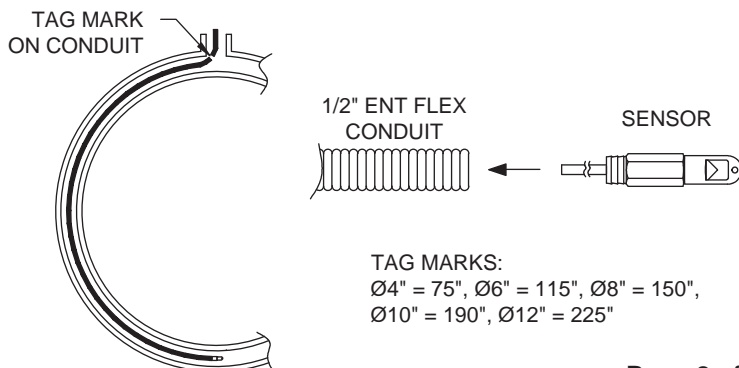

WIRING:

⚠ WARNING

Refer to console installation manual for WARNINGS and CAUTIONS before proceeding. FAILURE TO COMPLY MAY RESULT IN PERSONAL INJURY, PROPERTY LOSS AND EQUIPMENT DAMAGE.

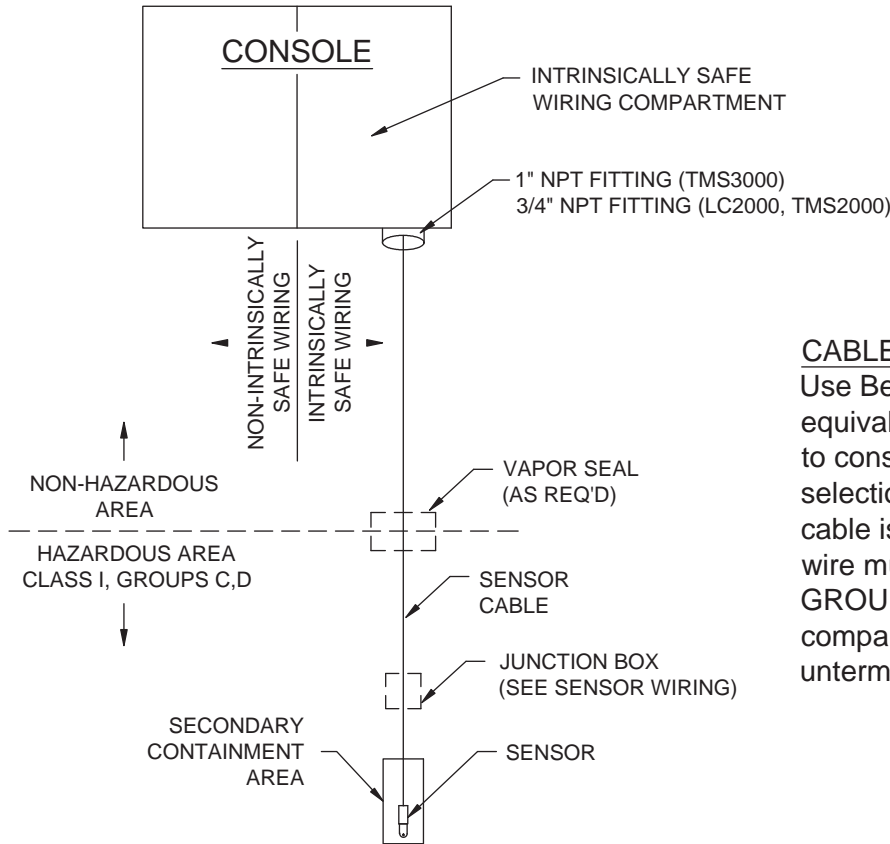

CABLE SELECTION:

Use Belden 8443, or Alpha 1173C or any equivalent 3-conductor, 22 AWG cable, refer to console installation manual for more cable selection and limitation information. Shielded cable is not required, but if used, the shield wire must be connected to the **SENSOR GROUND TERMINAL** in the console I.S. compartment and should be cut back and left unterminated at the sensor junction box.

TYPICAL WIRING FOR SENSOR

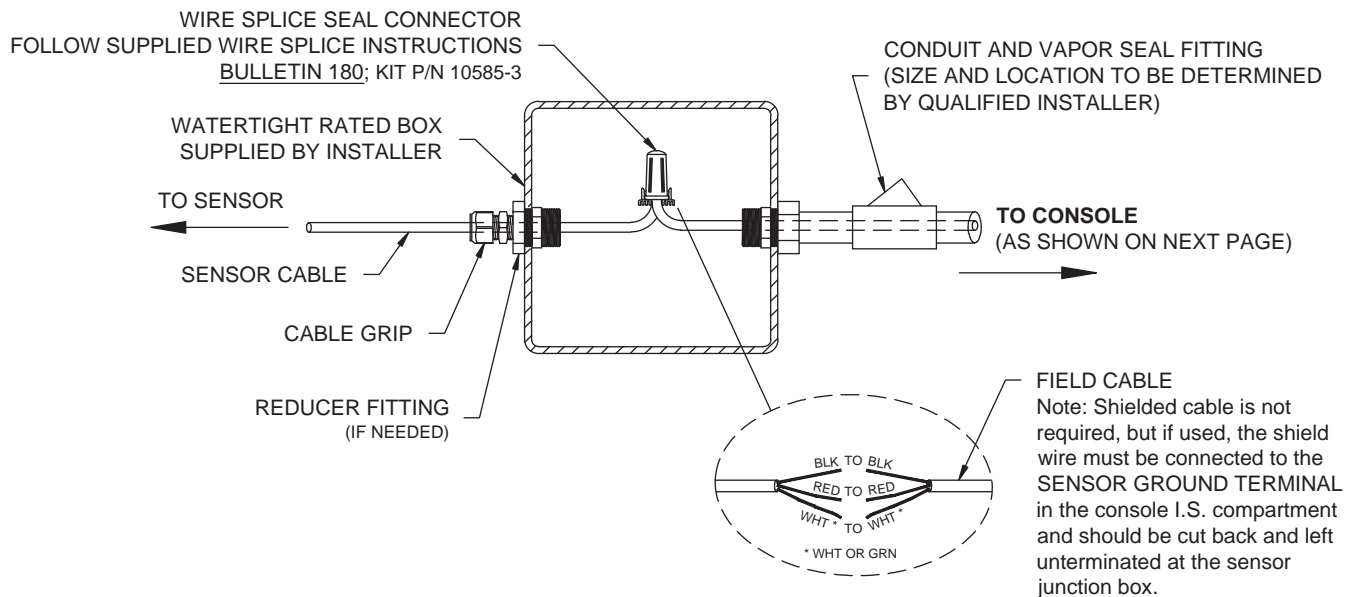

WIRING CONT'D:

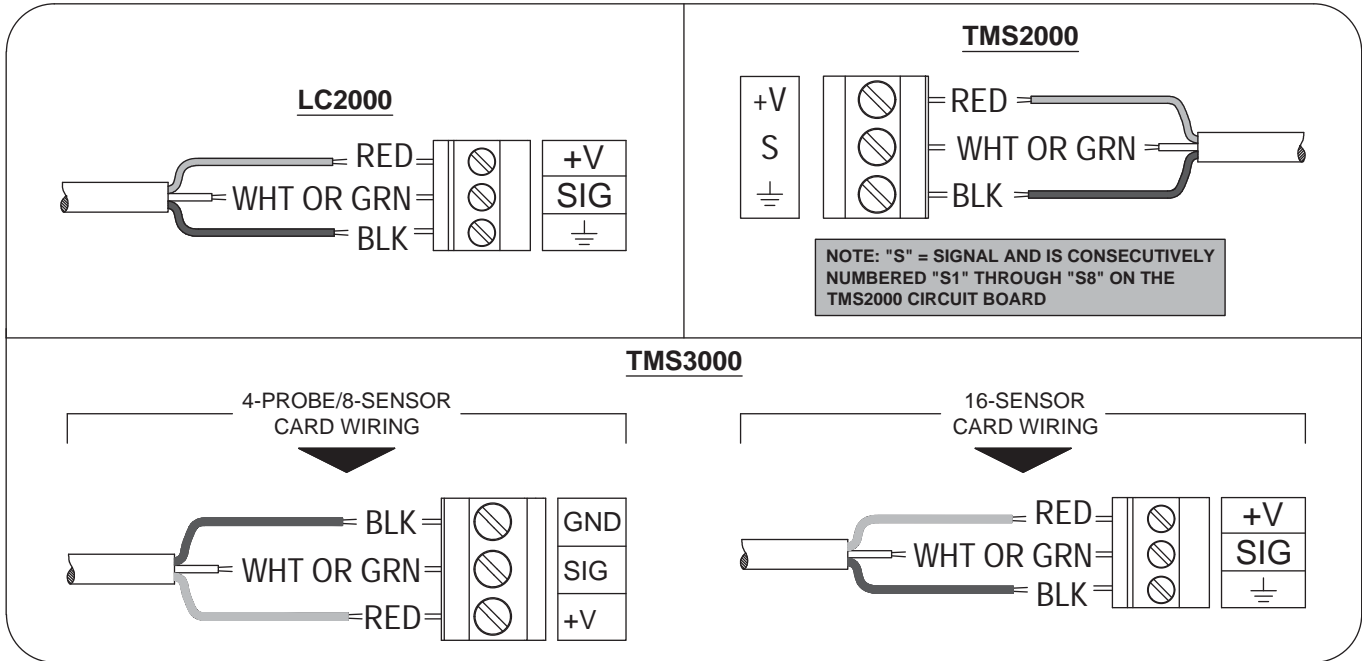

LC2000/TMSCOMM SOFTWARE PROGRAMMING: Configure the console to activate the installed sensor(s). Programming is as follows for Models LC2000, TMS2000 and TMS3000.

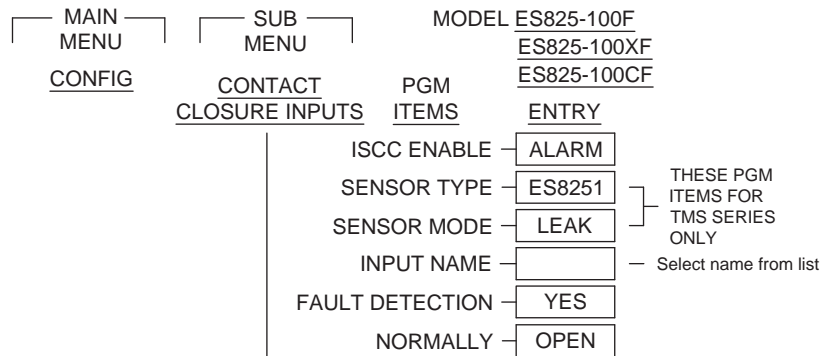

LC2000 FRONT PANEL PROGRAMMING: Configure the LC2000 to activate the installed sensor(s).

MODEL ES825-100F, ES825-100XF
ES825-100CF

PROGRAM Mode LED Indicators		ENTRY
SENSOR	OFF = DISABLED, ON (2 Fast Blinks) = ALARM, ON (3 Slow Blinks) = RELAY	ALARM
NO/NC	OFF = NC, ON = NO	ON
FAULT DETECT	OFF = DISABLED, ON = ENABLED	ON

TMS SERIES FRONT PANEL PROGRAMMING: Configure the TMS to activate the installed sensor(s). Programming is as follows for Models TMS2000 and TMS3000.

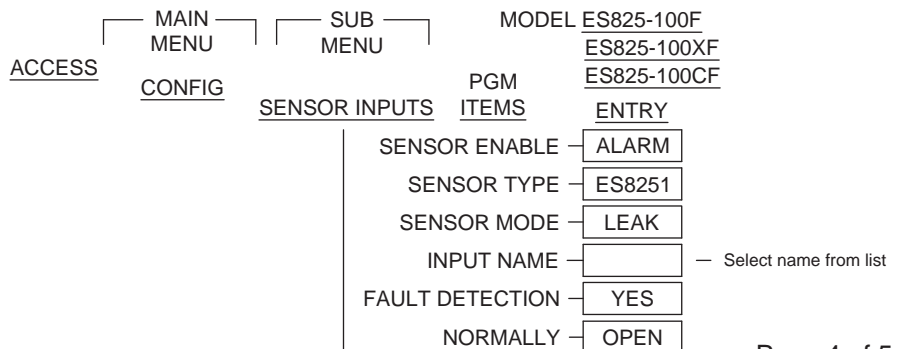

MAINTENANCE PROCEDURES: It is recommended practice to annually test sensor(s) to ensure proper operation.

1. Place sensor in cup/container of water or fuel. If testing in ambient light:
 - a) Container **MUST** be non-reflective.
 - b) Cover container with a rag/cloth.
2. While in the water or fuel, confirm that sensor is wired to the appropriate programmed input(s).
 - a) Error 20: Open.
 - b) Error 21: Closed/Short.
3. Dry sensor with a rag/cloth.

WARRANTY: Contact Pneumercator for official warranty policy.

 **WARNING**

DO NOT LEAVE SENSOR IN THE ALARM STATE FOR PROLONGED PERIODS DAMAGE MAY OCCUR WHICH IS NOT COVERED BY WARRANTY.