

MP461SC Flex Probes* Installation Instructions

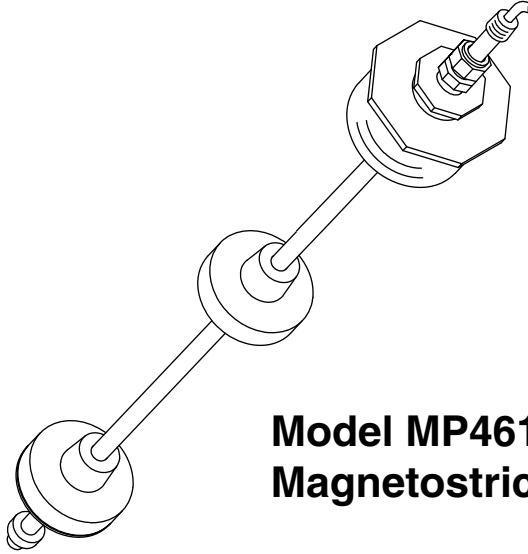

**Model MP461SC
Magnetostrictive Flex Probes**

**For use with the
following consoles:**

TMS2000	TMS3000
NOTE: MP461SC PROBES ARE NOT COMPATIBLE WITH TMS1000 SERIES AND Wireless DATA ACQUISITION MODULE (WiDAM) USED IN CONJUNCTION WITH WIRELESS CONSOLES. REFER TO MP561SC.	

*** NOTE:**
BEFORE USING THIS BULLETIN, VERIFY MODEL NUMBER ON PROBE TAG IS MP461SC.

© COPYRIGHT 2012 PNEUMERCATOR CO., INC.

TEL: (631) 293-8450
FAX: (631) 293-8533
WEBSITE: www.pneumercator.com
PNEUMERCATOR TECHNICAL SUPPORT
1 (800) 209-7858

GENERAL SYSTEM OVERVIEW: Figure 1 shows a block diagram of how the system should be configured for installation. It is supplied as a guide to planning the installation.

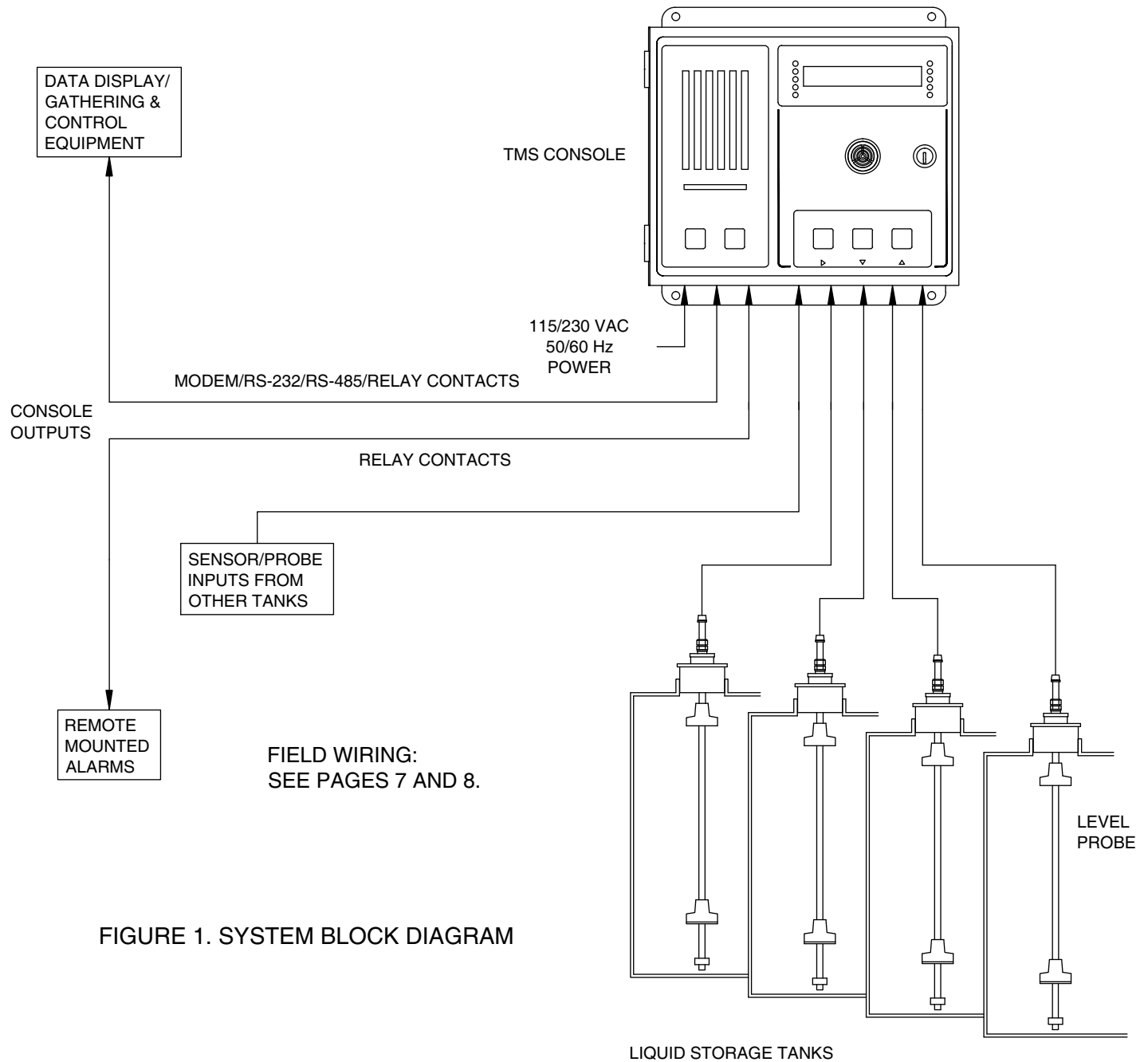

FIGURE 1. SYSTEM BLOCK DIAGRAM

⚠ WARNING

Refer to TMS installation manual for WARNINGS and CAUTIONS before proceeding. FAILURE TO COMPLY MAY RESULT IN PERSONAL INJURY, PROPERTY LOSS AND EQUIPMENT DAMAGE.

PRODUCT DESCRIPTION: MP461SC level gauging probes utilize proven magnetostrictive technology for accuracy and reliability. Probes are supplied with (1) product float for product level gauging and optionally (1) interface float for bottom water gauging. Additionally the probe contains either (1) or (5) thermistors for temperature measurement.

MODEL NO.	OAL (IN.) (Overall Length)	BOTTOM CLEARANCE (IN.)	BOTTOM DEADBAND DIMENSION (IN.)
MP461SC	55 - 150	.50	3.00

2-COND., 22 AWG CABLE, 10 FEET LONG	
COLOR	FUNCTION
BLACK	COM/GND (-)
RED	POWER (+)
DRAIN/SHIELD	DRAIN/SHIELD

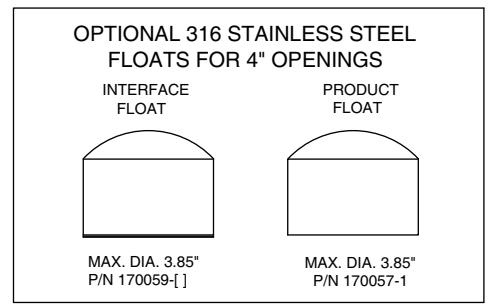
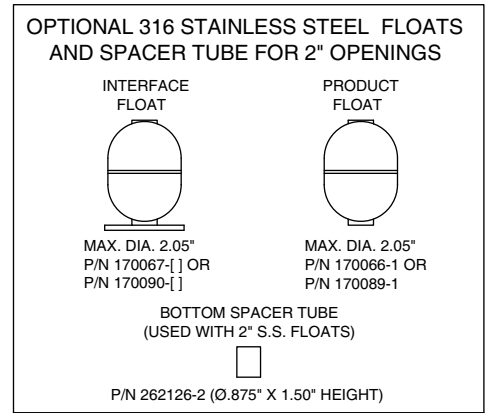
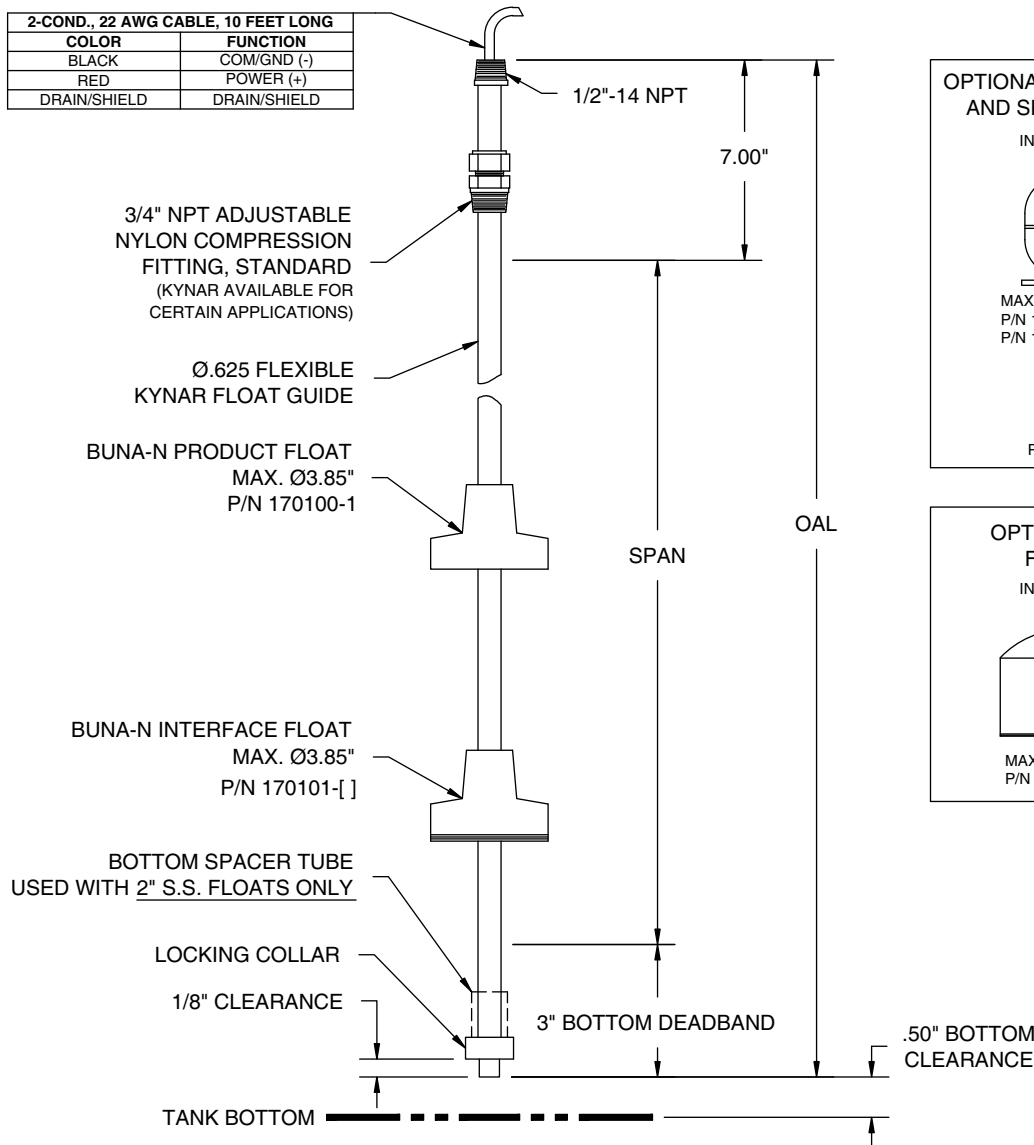

APPLICATIONS: The MP461SC Flex Probes are generally used for inventory management of tanks up to 12.5 feet tall where installation of a rigid probe is not possible due to a low ceiling clearance or chemical incompatibility.

UNPACKING: All probes should be visually inspected regardless of their shipping tube physical condition at delivery. Contact PNEUMERCATOR and the shipping company immediately if any of the parts (see page 4) are missing or damaged. During inspection and removal of the probe from the shipping carton, IMPORTANT: DO NOT LIFT THE PROBE BY IT'S ELECTRICAL CABLE! DO NOT BEND THE TOP 7 OR BOTTOM 3 INCHES OF THE PROBE! DO NOT REMOVE PROBE TAG! Consult the factory if you are not sure that the parts you received are suitable for your application.

PNEUMERCATOR SUPPLIED COMPONENTS:

(NOT SHOWN TO SCALE)

CUSTOMER SUPPLIED COMPONENTS:

(NOT SHOWN TO SCALE)

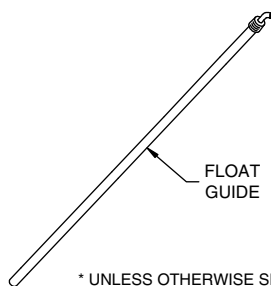

PROBE *
Overall Length (OAL) as required from table on page 3.

DO NOT BEND THE TOP 7 OR BOTTOM 3 INCHES OF THE PROBE!

* UNLESS OTHERWISE SPECIFIED, PROBE IS SUPPLIED FULLY ASSEMBLED WITH THE COMPRESSION FITTING, BUSHING, COLLAR AND FLOAT(S).



ADJUSTABLE NYLON COMPRESSION FITTING, STANDARD (KYNAR AVAILABLE FOR CERTAIN APPLICATIONS)

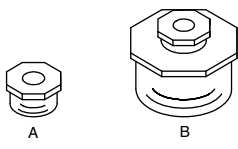

PVC BUSHING *
Either A or B supplied
A = 2" opening
B = 4" opening

* CHECK COMPATIBILITY. OPTIONAL METAL MOUNTING COMPONENTS SHOWN ABOVE (UPPER RIGHT) MAY BE USED FOR CERTAIN CHEMICAL APPLICATIONS.

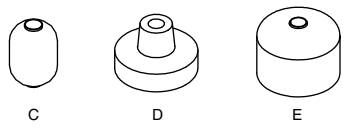

PRODUCT FLOAT
Either C, D or E supplied
C = 2" opening or greater
D, E = 4" opening or greater

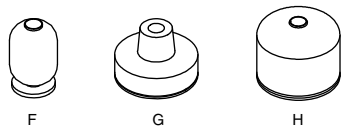

INTERFACE FLOAT *
Either F, G or H supplied
F = 2" opening or greater
G, H = 4" opening or greater

* IF CONFIGURED FOR DUAL FLOAT OPERATION.



BOTTOM SPACER TUBE
Used with 2" S.S. floats ONLY



LOCKING COLLAR
If collar is disassembled, reattach to probe leaving a 1/8" clearance as shown on page 3

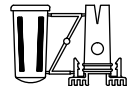

WIRE SPLICE SEAL CONNECTOR
(Installation instructions included with connector)

OPTIONAL METAL MOUNTING COMPONENTS



2" X 3/4" NPT BUSHING

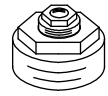

BUSHING ASSEMBLY
Example: 4" X 2" NPT and 2" X 3/4" NPT bushings assembled for threaded openings greater than 2" NPT

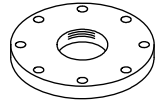

MATING FLANGE
An appropriate bushing size must be used to connect the probe if the flange threaded opening is greater than 3/4" NPT.

JUNCTION BOX OPTIONS

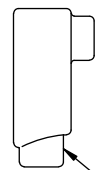

1/2" NPT OR AS REQUIRED TYP

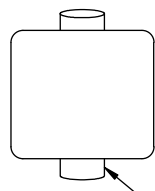

1/2" NPT OR AS REQUIRED TYP

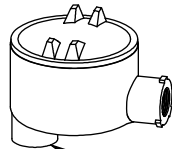

1/2" NPT OR AS REQUIRED TYP

NOTE:
A QUALIFIED INSTALLER, FAMILIAR WITH LOCAL WIRING CODES AND EXPLOSION HAZARD ELECTRICAL PRACTICES MAY CONCLUDE THAT JUNCTION BOXES ARE NOT REQUIRED FOR CERTAIN INDOOR INSTALLATIONS. HOWEVER, WATERTIGHT BOXES MUST BE INSTALLED FOR ALL OUTDOOR INSTALLATIONS.

INSTALLATION:

WARNINGS:

- Installation is only recommended at temperatures 30°F or above. Probe damage may occur as a result of handling at lower temperatures, voiding warranty.
- Installation must be done by a qualified person, familiar with local wiring codes and explosion hazard electrical practices.
- While handling the probe and during installation, **DO NOT CUT OR MODIFY THE PROBE. DO NOT LIFT THE PROBE BY IT'S ELECTRICAL CABLE! DO NOT BEND THE TOP 7 OR BOTTOM 3 INCHES OF THE PROBE! DO NOT REMOVE PROBE TAG!**
- Probe mounting location should be selected to minimize effect from turbulence. **DO NOT LOCATE IN A DIRECT LINE OF INBOUND OR OUTBOUND FLOW.**

- 1** Normally the probe is shipped fully assembled and ready for installation. However, if needed, assemble the supplied components as required before proceeding.

⚠ CAUTION

It is the **INSTALLERS RESPONSIBILITY** to ensure that they are adequately supported when handling the probe on top of the tank. **FAILURE TO COMPLY MAY RESULT IN PERSONAL INJURY, PROPERTY LOSS AND EQUIPMENT DAMAGE.**

- 2** **INSTALL PROBE:** Loosen the compression nut (see detail on page 6) at the top of the probe, enough to slide it along the probe. Carefully feed the probe through the tank opening as shown below. **THE PROBE CONTAINS ELECTRONICS. DO NOT BEND THE TOP 7 OR BOTTOM 3 INCHES OF THE PROBE! DO NOT REMOVE PROBE TAG!**

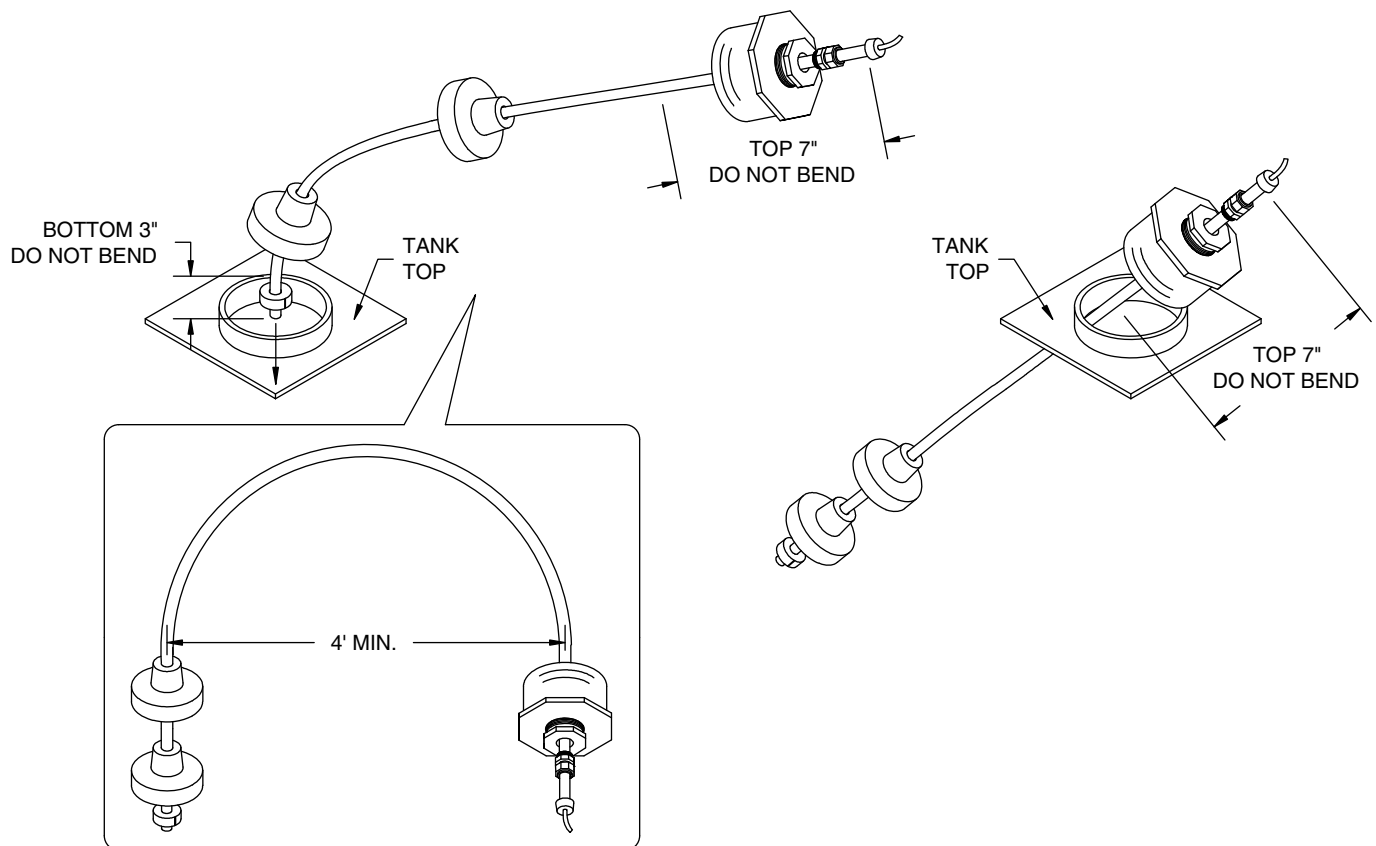

INSTALLATION CONT'D:

3 SECURE PROBE

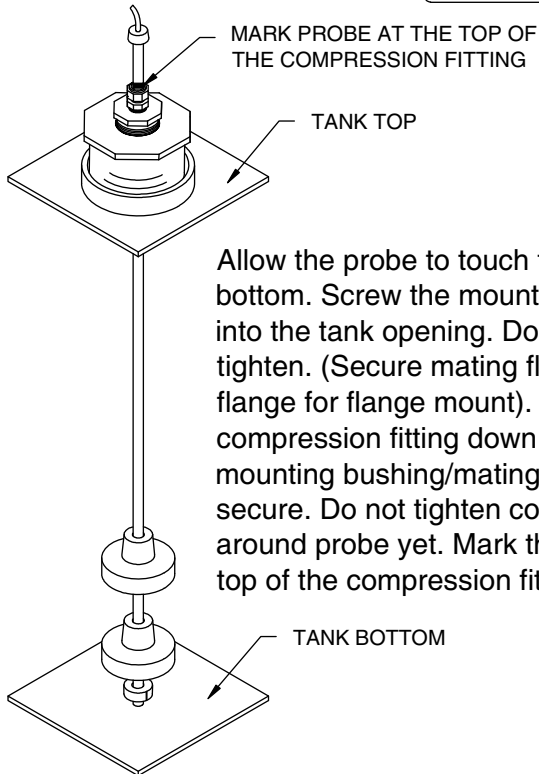
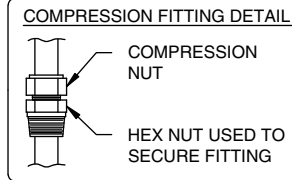

Allow the probe to touch the tank bottom. Screw the mounting bushing into the tank opening. Do not over tighten. (Secure mating flange to tank flange for flange mount). Slide the compression fitting down to the mounting bushing/mating flange and secure. Do not tighten compression nut around probe yet. Mark the probe at the top of the compression fitting as shown.

4 SET BOTTOM CLEARANCE

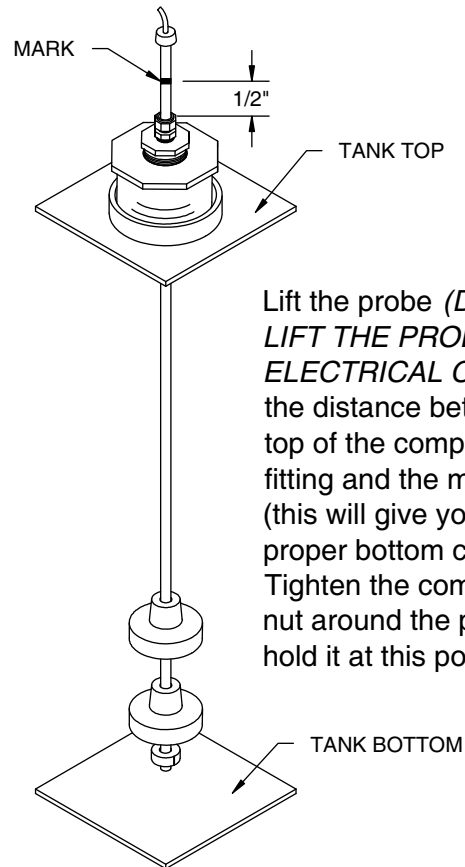

Lift the probe (*DO NOT LIFT THE PROBE BY IT'S ELECTRICAL CABLE*) until the distance between the top of the compression fitting and the mark is 1/2" (this will give you the proper bottom clearance). Tighten the compression nut around the probe to hold it at this point.

5 INSTALL HOUSING: A qualified installer, familiar with local wiring codes and explosion hazard electrical practices, may conclude that this step is not required for certain indoor installations. However, watertight boxes must be installed for all outdoor installations.

WARNINGS

- DO NOT ALLOW CONDUIT WEIGHT LOAD TO BE APPLIED TO PROBE.
- HAND TIGHTEN HOUSING WHILE SECURING PROBE HEX FITTING NUT.
- DO NOT BEND OR STRAIN PROBE WHEN CONNECTING CONDUIT.

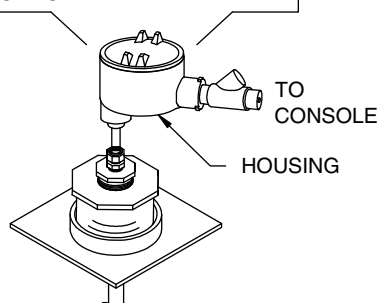

WIRING:

⚠ WARNING

Refer to TMS installation manual for WARNINGS and CAUTIONS before proceeding. FAILURE TO COMPLY MAY RESULT IN PERSONAL INJURY, PROPERTY LOSS AND EQUIPMENT DAMAGE.

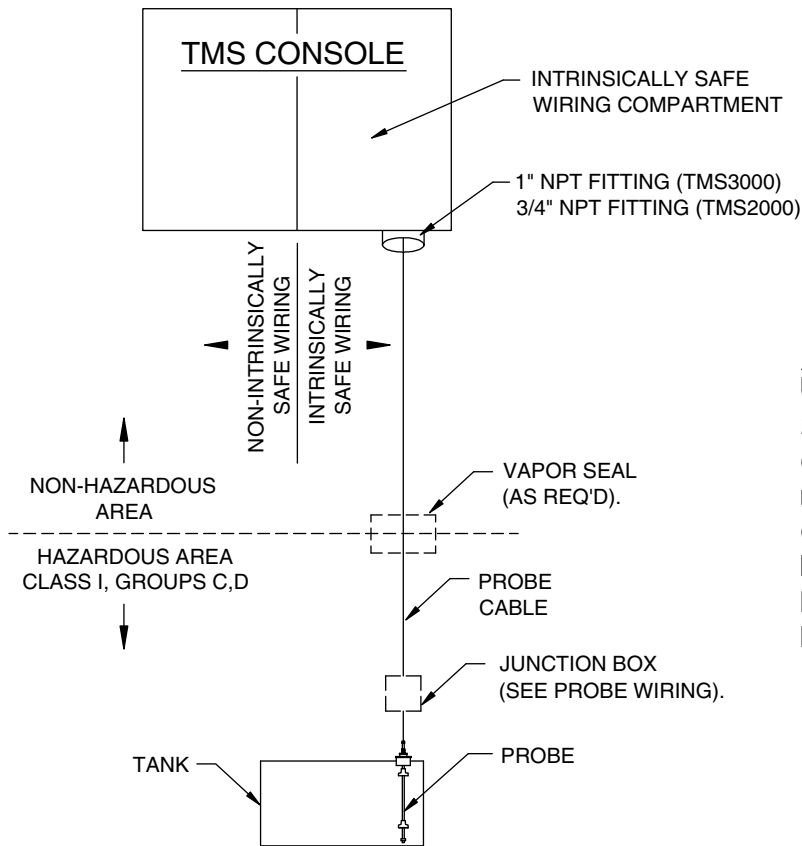

FIELD WIRING CABLE SELECTION:

Use Belden 8441, or any equivalent 2-conductor, 22 AWG shielded, twisted-pair cable, refer to TMS installation manual for more cable selection information. The field cable shield wire must be connected to the PROBE SHIELD TERMINAL in the console I.S. compartment and should be cut back and left unterminated at the probe junction box.

TYPICAL JUNCTION BOX WIRING

WIRE SPLICE SEAL CONNECTOR
FOLLOW SUPPLIED WIRE SPLICE INSTRUCTIONS
BULLETIN 179; KIT P/N 10585-2

WATERTIGHT RATED BOX
NOT REQ'D IF DETERMINED BY
QUALIFIED INSTALLER
(SEE STEP 5 ON PAGE 6)

CONDUIT AND VAPOR SEAL FITTING
(SIZE AND LOCATION TO BE DETERMINED
BY QUALIFIED INSTALLER)

TO CONSOLE
(AS SHOWN ON NEXT PAGE)

- WARNINGS**
- DO NOT ALLOW CONDUIT WEIGHT LOAD TO BE APPLIED TO PROBE.
 - HAND TIGHTEN HOUSING WHILE SECURING PROBE HEX FITTING NUT.
 - DO NOT BEND OR STRAIN PROBE WHEN CONNECTING CONDUIT.

PROBE CABLE
PROBE FITTING

FIELD CABLE
Note: The field cable shield wire must be connected to the PROBE SHIELD TERMINAL in the console I.S. compartment and should be cut back and left unterminated at the probe junction box.

BLK TO BLK
RED TO RED

WIRING CONT'D:

TYPICAL WIRING FOR TMS CONSOLES

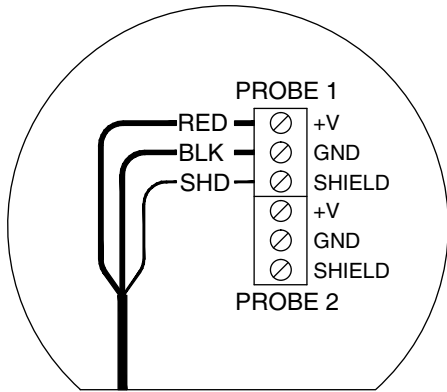

TMS2000 PROBE INPUT WIRING

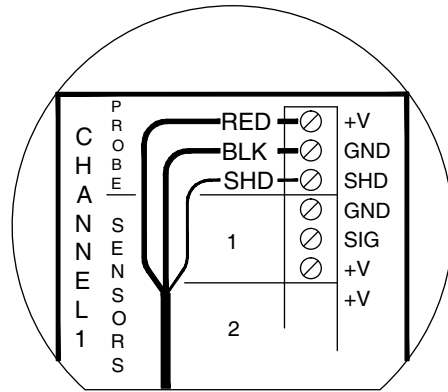

TMS3000 PROBE INPUT WIRING

PROGRAMMING: Information necessary for programming this probe can be found on the tag attached to the probe. One side of the tag has certification information and the other side has information needed to program the TMS console to enable this probe. Copy the information from the tag on the probe onto this sheet and onto the tank worksheet in the TMS Operation Manual for referencing when programming the TMS. If you have more than 6 probes, make a copy of this sheet. USE THE EFFECTIVE LENGTH GIVEN ON THE TAG WHEN PROGRAMMING THE SYSTEM PROBE LENGTH PARAMETER. THE "SC" ON THE PROBE TYPE IS NOT NEEDED FOR PROGRAMMING.

PROBE TAG EXAMPLE
(BOTTOM SECTION)

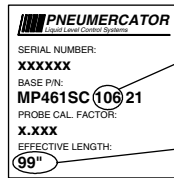

DO NOT USE FOR PROGRAMMING

USE THIS VALUE FOR PROGRAMMING

PROBE NAME, LOCATION OR DESCRIPTION: _____

SERIAL NO. _____

P/N: MP461SC _____

Probe Cal. Factor: _____

Probe Type: MP461SC

Effective Length: _____

PROBE NAME, LOCATION OR DESCRIPTION: _____

SERIAL NO. _____

P/N: MP461SC _____

Probe Cal. Factor: _____

Probe Type: MP461SC

Effective Length: _____

PROBE NAME, LOCATION OR DESCRIPTION: _____

SERIAL NO. _____

P/N: MP461SC _____

Probe Cal. Factor: _____

Probe Type: MP461SC

Effective Length: _____

PROBE NAME, LOCATION OR DESCRIPTION: _____

SERIAL NO. _____

P/N: MP461SC _____

Probe Cal. Factor: _____

Probe Type: MP461SC

Effective Length: _____

PROBE NAME, LOCATION OR DESCRIPTION: _____

SERIAL NO. _____

P/N: MP461SC _____

Probe Cal. Factor: _____

Probe Type: MP461SC

Effective Length: _____

PROBE NAME, LOCATION OR DESCRIPTION: _____

SERIAL NO. _____

P/N: MP461SC _____

Probe Cal. Factor: _____

Probe Type: MP461SC

Effective Length: _____