

## RSU800-2 Reservoir Sensor Installation Instructions

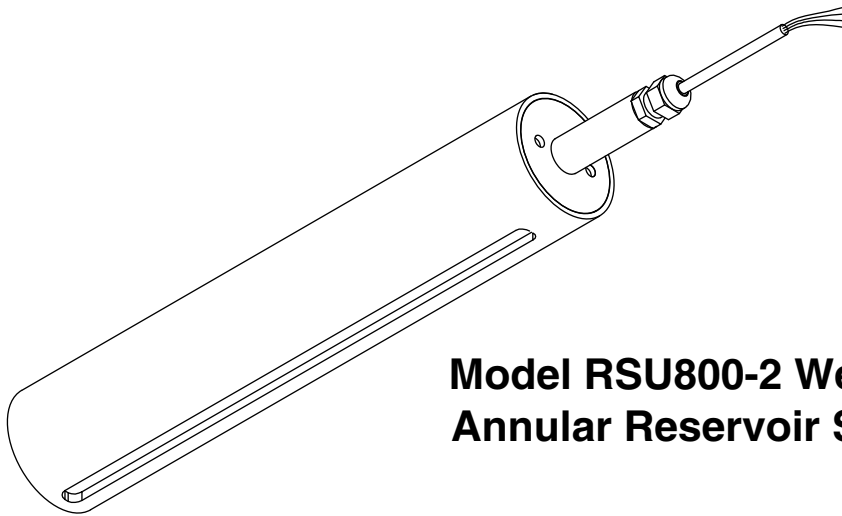

**Model RSU800-2 Wet  
Annular Reservoir Sensor**

**For use with the  
following consoles:**

<b>LC2000</b>	<b>TMS2000</b>
<b>TMS3000</b>	

© COPYRIGHT 2008 PNEUMERCATOR CO., INC.

TEL: (631) 293-8450  
FAX: (631) 293-8533  
WEBSITE: [www.pneumercator.com](http://www.pneumercator.com)  
PNEUMERCATOR TECHNICAL SUPPORT  
1 (800) 209-7858

**PRODUCT DESCRIPTION:** Model RSU800-2 is a dual float normally closed sensor that detects level changes within the reservoir. A breach of the inner tank wall will trigger a high alarm, and a breach of the outer wall will trigger a low alarm as the reservoir level changes. Fluctuations due to temperature and barometric pressure changes should not trigger an alarm. The sensor can be wired as non-discriminating (one alarm for high and low levels) requiring (1) N.C. input, or as discriminating (individual alarms for high and low levels) requiring (2) N.C. inputs.

**APPLICATIONS:** This Secondary Containment Leak Sensor is designed to monitor brine or glycol fluid levels in fiberglass double wall tank reservoirs.

**INSTALLATION:**

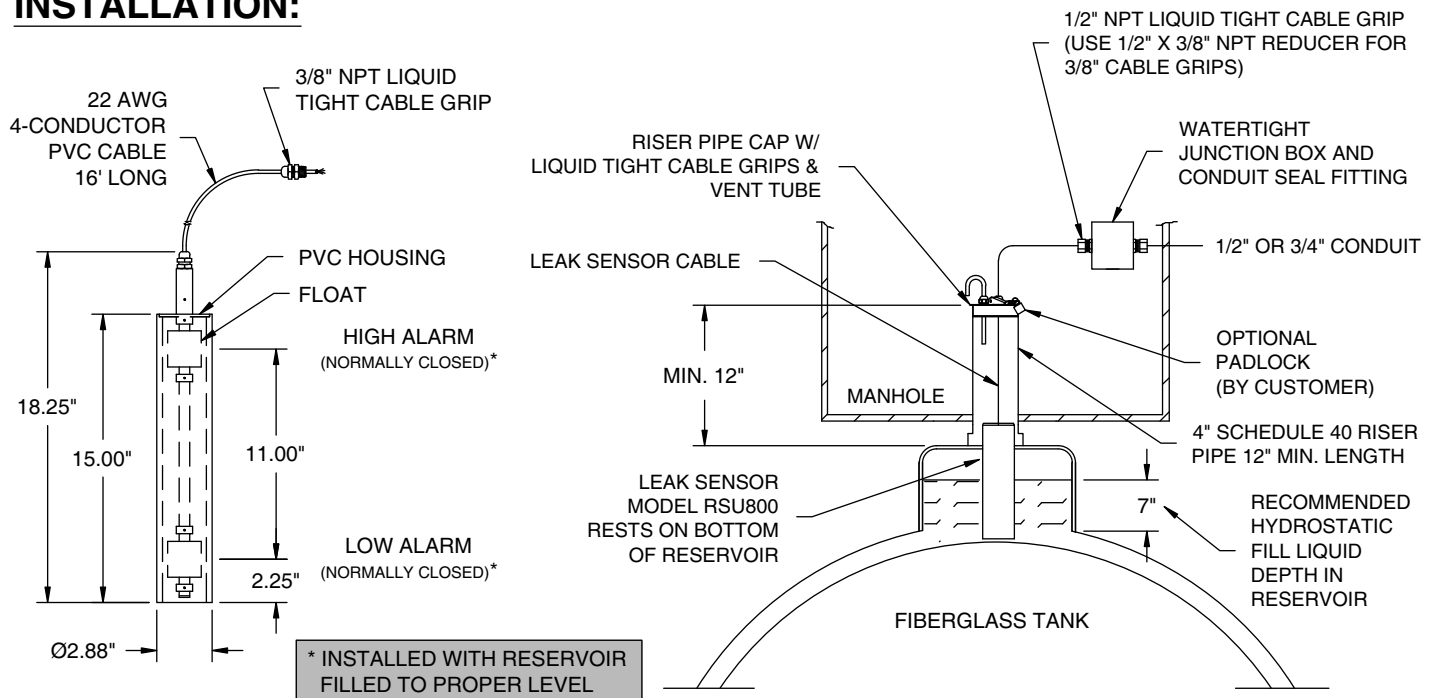

**NOTE:** Before installation, mark the sensor at 7" from the bottom. The reservoir level must be maintained at or very near this level to avoid false alarms due to level fluctuations.

1. All sensors must be tested before installation. Manually move the floats to set off the alarm from the high and low positions.
2. Fit the reservoir with a 4" RISER PIPE (12" min. length) and CAP, supplied by the installer. The riser cap should have a 3/8" NPT tapped hole to accept the cable grip connector supplied by PNEUMERCATOR. Use a riser pipe with a vent tube only if local installation codes require one.
3. Thread the supplied connector into the cap's tapped hole using sealing compound as required.
4. Slowly lower the sensor into the riser until it rests on the reservoir bottom. The top portion should extend into the riser pipe for support from tipping over. The liquid level in the reservoir should be at about 7 inches up the sensor's height for optimum performance.
5. Feed the sensor cable through the bottom of the connector in the cap. Leave just enough slack inside the riser pipe so the sensor remains on the bottom, and will not tip over.
6. Mate the riser and cap; then tighten the connector over the cable to ensure a watertight seal.

# WIRING:

## ⚠ WARNING

Refer to console installation manual for WARNINGS and CAUTIONS before proceeding. FAILURE TO COMPLY MAY RESULT IN PERSONAL INJURY, PROPERTY LOSS AND EQUIPMENT DAMAGE.

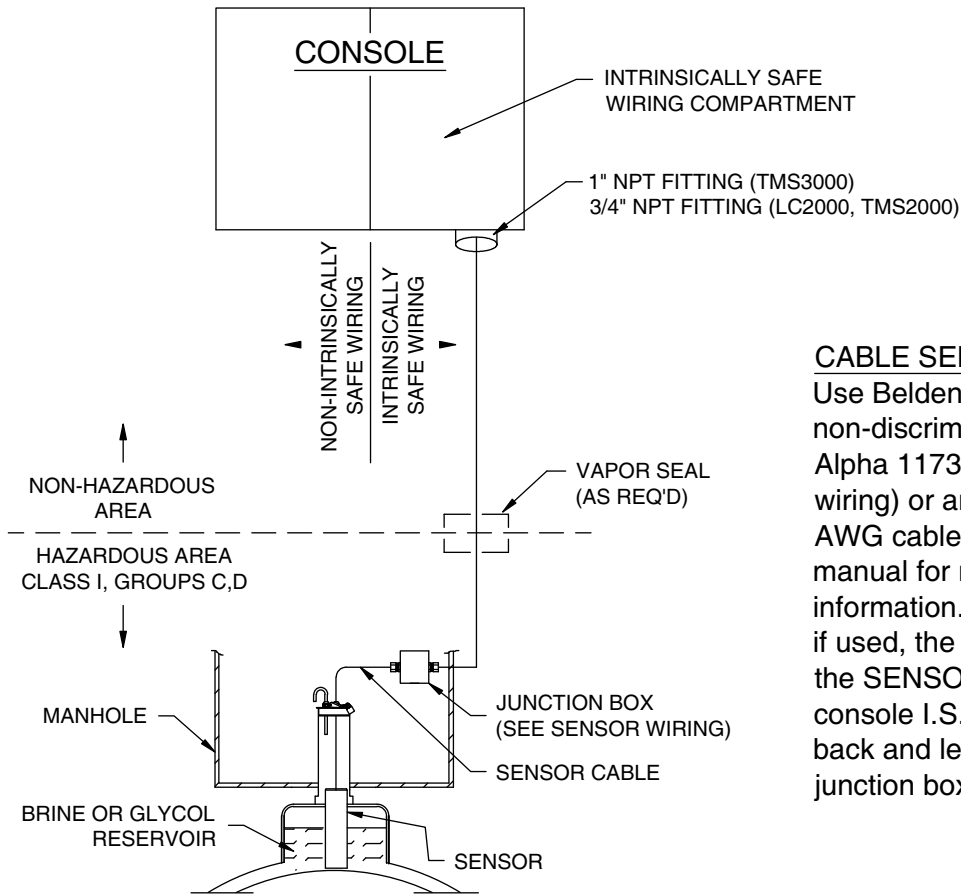

### CABLE SELECTION:

Use Belden 8442 or Alpha 1172C (2-cond. for non-discriminating wiring), Belden 8443 or Alpha 1173C (3-cond. for discriminating wiring) or any equivalent 2 or 3-conductor, 22 AWG cable, refer to console installation manual for more cable selection and limitation information. Shielded cable is not required, but if used, the shield wire must be connected to the SENSOR GROUND TERMINAL in the console I.S. compartment and should be cut back and left unterminated at the sensor junction box.

### TYPICAL WIRING FOR SENSOR

WIRE SPLICE SEAL CONNECTOR  
FOLLOW SUPPLIED WIRE SPLICE INSTRUCTIONS  
BULLETIN 180; KIT P/N 10585-3

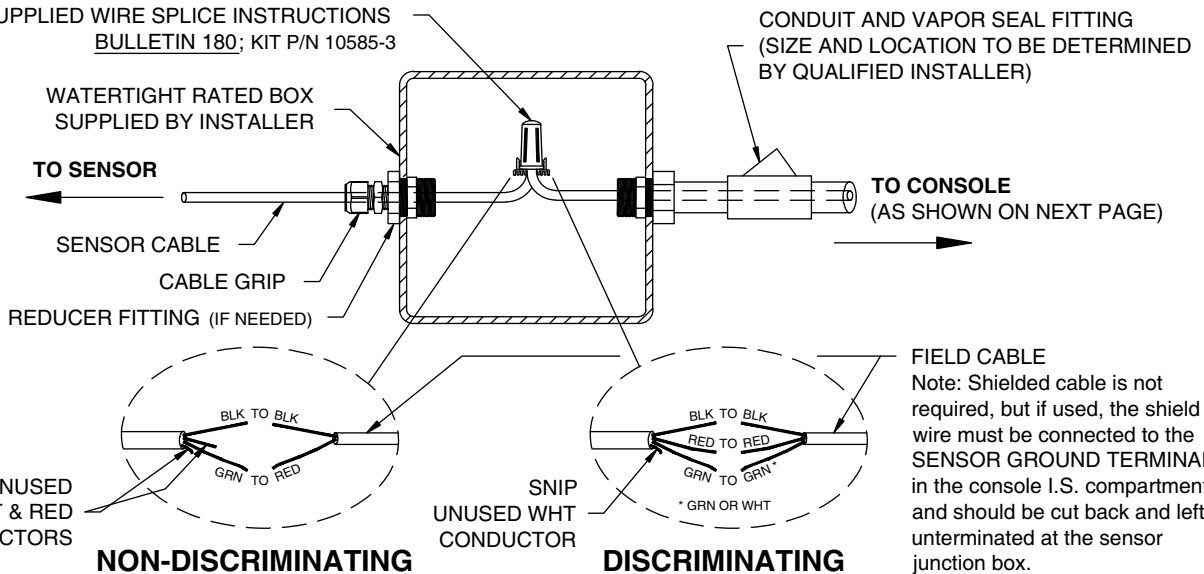

# WIRING CONT'D:

## CABLE COLOR CODES

FUNCTION	SENSOR CABLE	FIELD CABLE (DISCRIMINATING WIRING)	FIELD CABLE (NON-DISCRIMINATING WIRING)
HIGH	GREEN	GRN OR WHT (SEE PAGE 3)	RED (SEE PAGE 3)
LOW	BLACK	BLACK	BLACK
COMMON	RED	RED	-

### LC2000 SENSOR INPUT WIRING (NOTE: SENSOR CABLE COLORS SHOWN)

#### DISCRIMINATING

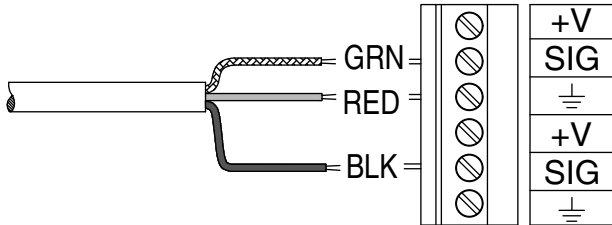

#### NON-DISCRIMINATING

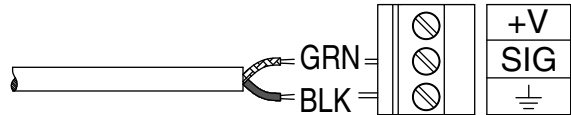

### TMS2000 SENSOR INPUT WIRING (NOTE: SENSOR CABLE COLORS SHOWN)

#### DISCRIMINATING

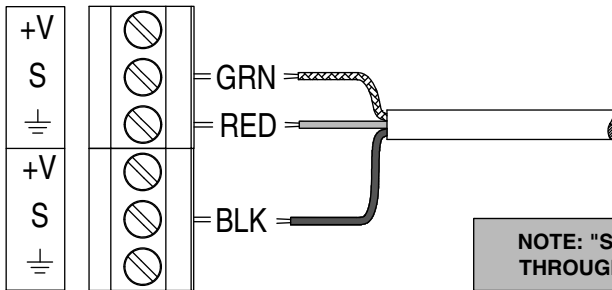

#### NON-DISCRIMINATING

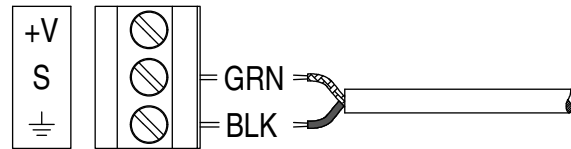

NOTE: "S" = SIGNAL AND IS CONSECUTIVELY NUMBERED "S1" THROUGH "S8" ON THE TMS2000 CIRCUIT BOARD

### TMS3000 SENSOR INPUT WIRING (NOTE: SENSOR CABLE COLORS SHOWN)

#### DISCRIMINATING

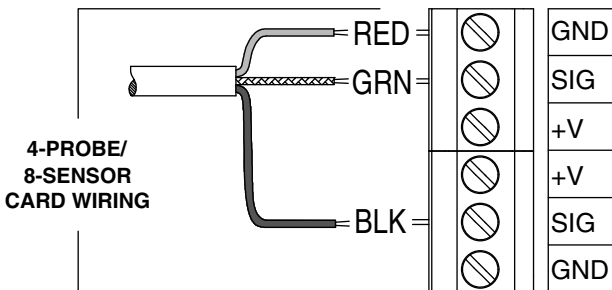

#### NON-DISCRIMINATING

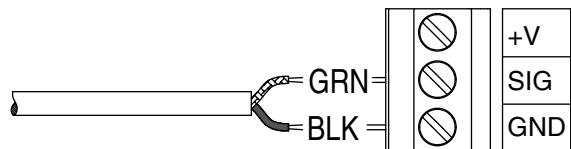

NOTE THE REVERSE ORDERING OF SENSOR INPUT NAMES

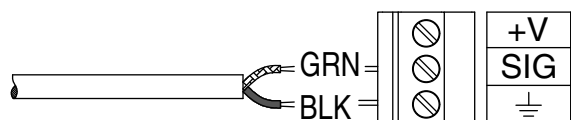
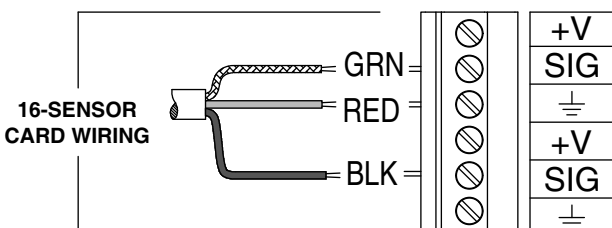

**LC2000 PROGRAMMING:** Configure the LC2000 to activate the installed monitoring sensors.

Programming can be accomplished from the LC2000 front panel. Refer to installation manual and/or label located inside the console behind the front door for additional programming information.

MODEL RSU800-2

PROGRAM Mode LED Indicators	
SENSOR	OFF = DISABLED, ON (2 Fast Blinks) = ALARM, ON (3 Slow Blinks) = RELAY
NO/NC	OFF = NC, ON = NO
FAULT DETECT	OFF = DISABLED, ON = ENABLED

ENTRY

ALARM

OFF

OFF

**TMS PROGRAMMING:** Configure the TMS to activate the installed monitoring sensors. Programming can be accomplished either from the TMS front panel or via TMSCOMM software. Programming is as follows for both Model TMS2000 and Model TMS3000.

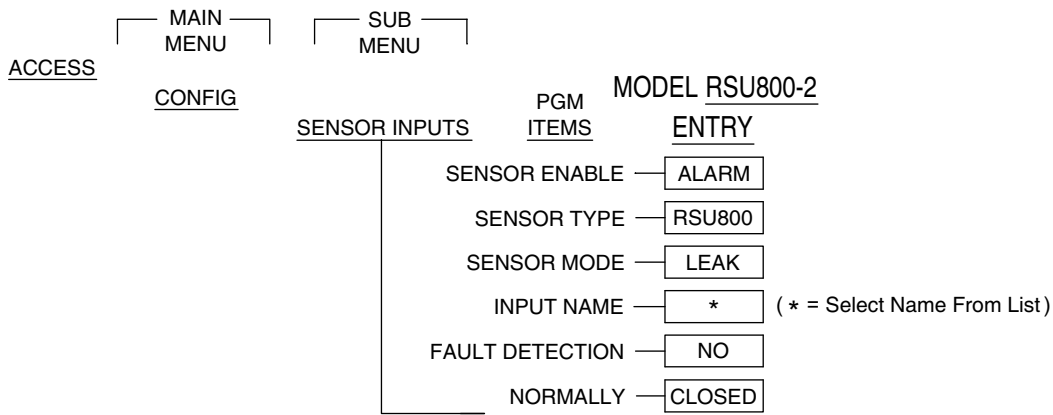

**PERIODIC TESTING:** Test to ensure proper operation of sensor by performing the following steps:

1. Remove the sensor from the reservoir. This should activate the alarm from the low level position.
2. Move the float to the middle, no alarm condition. Reset any alarms on the control panel. The system should now be in normal condition.
3. Turn the sensor upside down to activate the high alarm. Reset the control panel.
4. Return the sensor to the reservoir.