

# 2" (51 mm) Riser Mounting Kit for MP45xS/MP55xS Magnetostrictive Tank Gauging Probes

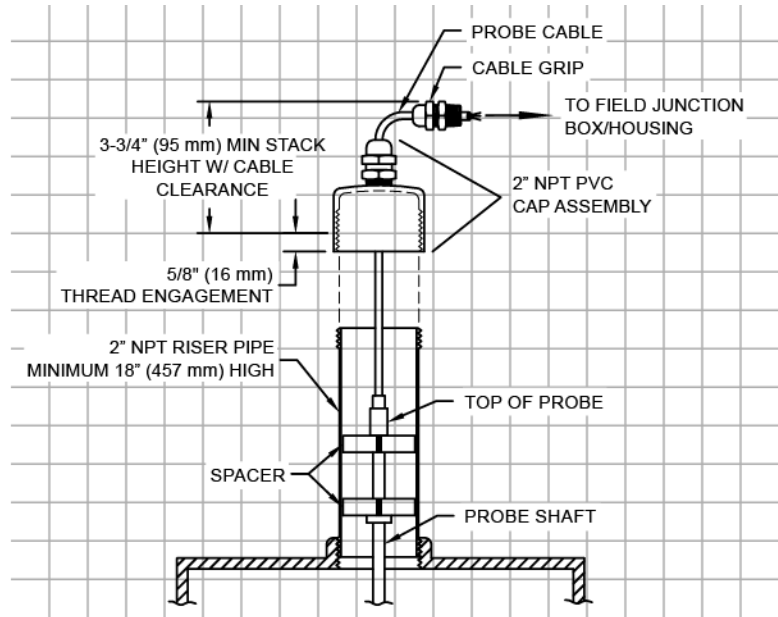
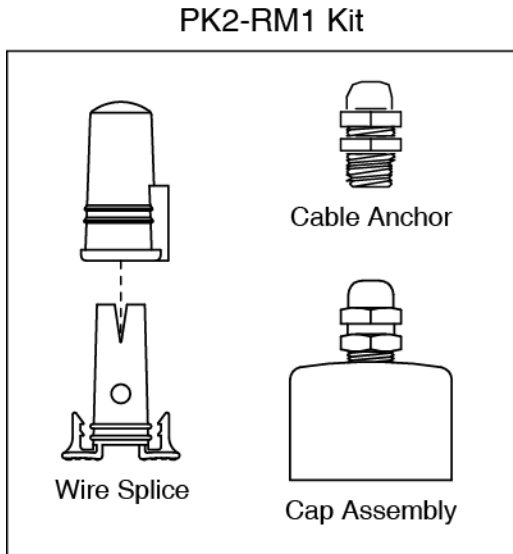

## Product Description

The PK2-RM Riser Mount Probe Kit provides a “soft-mount” method of installation by allowing the probe to rest on the tank bottom and be stabilized within the tank riser without attachment. This method may be used for MP45xS/MP55xS series probe lengths up to 15 feet (4.6 m), providing easy installation and servicing by simply removing cap and lowering or raising probe by its cable. The standard kit includes a 2” PVC cap assembly with integral cable compression fitting, cable compression fitting for field junction box and wire splice kit. **IMPORTANT:** Use PK2-DM Direct Mount Kit for probe lengths exceeding 15 feet (4.6 m). The riser mount should **not** be used in chemical or high heat applications without consulting factory.

## Applications

- Vertical Storage Tanks up to 15 Feet (4.6 m)
- Underground Storage Tanks
- Sub-Base Tanks

## Specifications

- Materials: Cap: PVC  
Bushing: 316SS  
Cable Compression Fitting: Nylon or PVDF Body, TPE or Teflon Rings
- Mount: 2” NPT riser pipe, minimum 18” (457 mm) height.
- Operating Pressure: 70 PSIG (483 kPa)

## Model Numbers

- PK2-RM1 (or RM) Schedule 80 PVC Cap, Nylon Cable Compression Fitting, TPE Rings (Stock, Standard)
- PK2-RM2 316SS Bushing, PVDF Cable Compression Fitting, Viton Rings (Special Order)
- PK2-RM3 316SS Bushing, Nylon Cable Compression Fitting, TPE Rings (Special Order)

Note: Specifications subject to change without notice. 04-01-2013