

INSTALLATION MANUAL

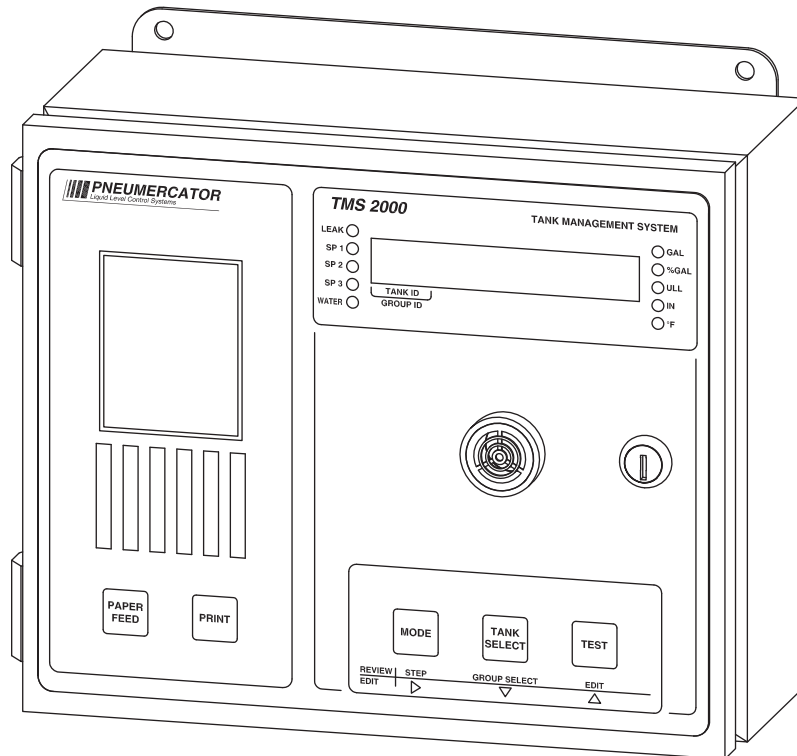

DRAWING NO. 20046 REV. N/C

MODEL TMS2000

**© COPYRIGHT 2013 PNEUMERCATOR CO., INC.
1785 EXPRESSWAY DRIVE NORTH
HAUPPAUGE, NY 11788**

TEL: (631) 293-8450
FAX: (631) 293-8533
<http://www.pneumercator.com>

Note: A separate OPERATING MANUAL is available, but NOT required for TMS2000 installation.

TABLE OF CONTENTS

	Page
SAFETY INFORMATION	1
Section 1 PRODUCT DESCRIPTION	
1.1 General System Overview.....	2
1.2 Control Console.....	3
1.3 Liquid Level Probes	5
1.4 Liquid Leak Sensors	6
Section 2 INSTALLATION DETAILS	
2.1 Installation Checklist.....	8
2.2 Control Console Installation	9
2.3 Level Probe Installation – Underground	10
2.4 Level Probe Installation – Above Ground	12
2.5 Leak Sensor Installation – Steel Tanks	16
2.6 Leak Sensor Installation – Piping Sumps and Dispenser Pans, Vaulted Tank	17
2.7 Leak Sensor Installation – Fiberglass Underground Tanks.....	18
2.8 Leak Sensor Installation – Fiberglass Underground Tank Reservoirs	19
Section 3 WIRING INSTALLATION AND DIAGRAMS	
3.1 System Intrinsic Safety Wiring.....	21
3.2 Power Wiring	26
3.3 Probe/Sensor Wiring & Splices	27
3.4 Programmable Relay Outputs/Contact Closure Inputs.....	32
3.5 Data Communications Wiring.....	33
3.6 Probe Map/System Setup	34

⚠ IMPORTANT SAFETY INFORMATION

This manual contains instructions for installing electrical hardware in explosion hazard areas.

The following warnings must be considered to be in compliance with accepted codes.

Any inquiries about this manual, or to return defective equipment should be directed to:

**PNEUMERCATOR COMPANY
1785 EXPRESSWAY DRIVE NORTH
HAUPPAUGE, NY 11788
Attention: Technical Services
TEL: (631) 293-8450
FAX: (631) 293-8533
TOLL FREE: (800) 209-7858
www.pneumercator.com**

⚠ WARNING

Installation must be in strict accordance with this manual as adopted from the following codes:

- ISA RP12.6, "Installation of intrinsically Safe Instrument Systems in Class I Hazardous Locations."
- UL - Underwriters Laboratories
- NFPA 70, "National Electric Code."
- NFPA 30A, "Automotive and Marine Service Station Code."

FAILURE TO COMPLY MAY RESULT IN PERSONAL INJURY, PROPERTY LOSS AND EQUIPMENT DAMAGE.

⚠ WARNING

Alteration, modification or replacement with non-factory components could impair the intrinsic safety of this equipment, void the warranty and void the UL Listing. **FAILURE TO COMPLY MAY RESULT IN PERSONAL INJURY, PROPERTY LOSS AND EQUIPMENT DAMAGE.**

SECTION 1 – PRODUCT DESCRIPTIONS

1.1 GENERAL SYSTEM OVERVIEW

The TMS2000 is a fully integrated tank monitor system that combines level measurement with precision in-tank leak detection and external sensors for secondary containment. Figure 1-1 shows a typical block diagram of how a system should be configured for installation. This diagram is not a detailed wiring diagram, which is found in Section 3 of this manual. Figure 1-1 is to guide the installer in planning the actual installation, and give a general overview of the possible combinations of TANKS, LEVEL PROBES, EXTERNAL SENSORS, and OPTIONAL equipment that may be required for a typical installation. Figure 1-1 shows only one (1) tank with three (3) sensors: however, TMS2000 can monitor up to 2 tanks and 8 sensor combinations. Refer to the specific design drawing for the customer's actual site for complete site-specific details on how many tanks and sensors are specified.

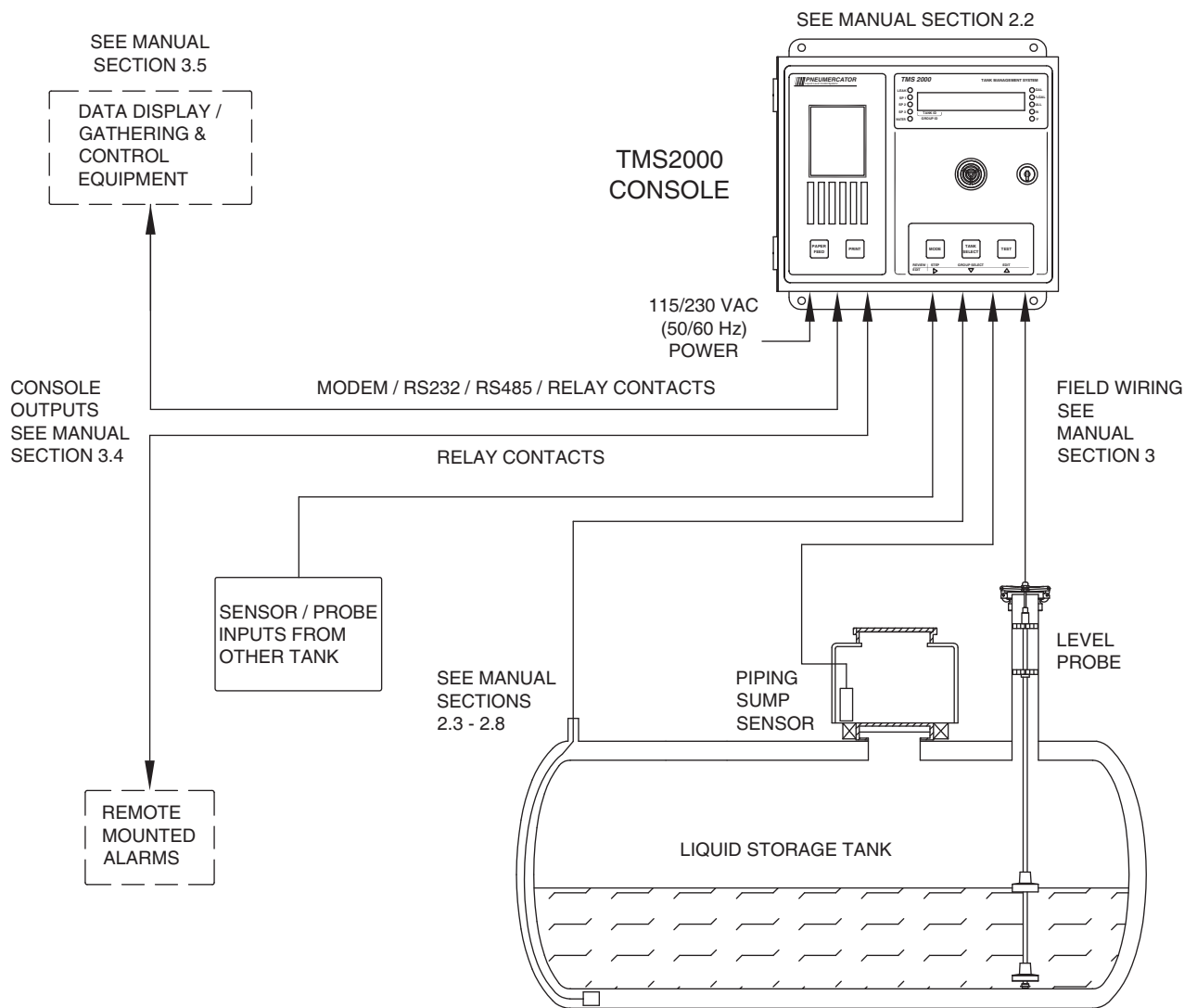

Figure 1-1 - Typical System Block Diagram

1.2 CONTROL CONSOLE DESCRIPTION

Figure 1-2 illustrates the standard TMS2000 outline and dimensions. All standard configurations are equipped with 2 mag. probe/8 leak sensor inputs, 1 RS-232 serial port, 1 RS-485 serial port, 2 Fully programmable Relay outputs/2 Dry contact inputs, NEMA 12 enclosure. There are four (4) basic configurations available:

TMS2000-1	“Black Box” Remote Acquisition Unit w/o display.
TMS2000-2	Front Panel Display w/o printer.
TMS2000-3	Front Panel Display with impact printer.
TMS2000-4	Front Panel Display with impact printer & autowinder.

⚠ WARNING

Installation MUST be done by qualified personnel familiar with local wiring codes and explosion hazard electrical safety practices. FAILURE TO COMPLY MAY RESULT IN PERSONAL INJURY, PROPERTY LOSS AND EQUIPMENT DAMAGE.

The standard TMS2000 console enclosure is NEMA 12-rated for indoor installation. An optional NEMA 4/4X enclosure is available for outdoor installation. Confirm enclosure rating on the approval label located on the exterior, left-hand side of the enclosure before installation outdoors. See Figure 1-2 below for mounting flange locations and dimensions.

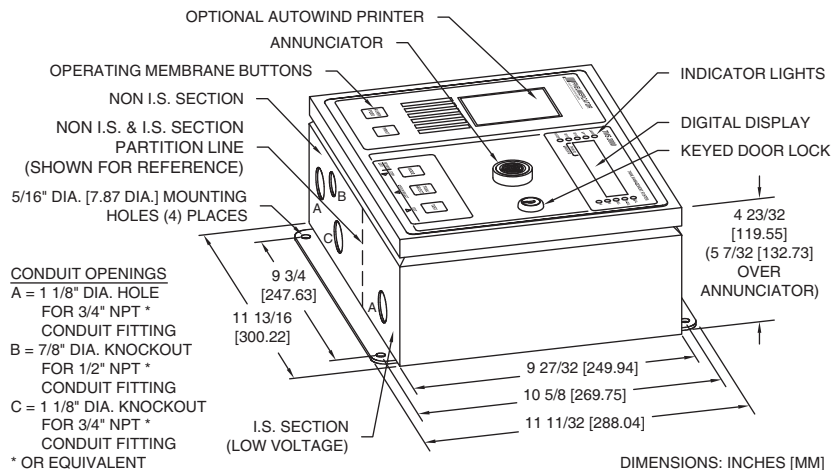

DIMENSIONS: INCHES [MM]
DRAWING NO. 20048 REV. N/C

Figure 1-2 - TMS2000 Console Outline

⚠ WARNING

The console is designed for Ordinary Location, Non-Hazardous installation only, as defined by Underwriters Laboratories (UL) and the National Electrical Code (NEC). DO NOT install where flammable vapors may be present. FAILURE TO COMPLY MAY RESULT IN PERSONAL INJURY, PROPERTY LOSS AND EQUIPMENT DAMAGE.

The console should be located in an area that is easily accessible to the personnel responsible for operation and maintenance of the system. Metal conduiting is recommended and may be required by local codes. All outdoor conduits must be watertight.

All conduit entries are provided on the bottom of the enclosure. Remove conduit knockouts only for those entries being used. If a knockout is removed but the entry will not be used, it must be sealed with an appropriate plug.

⚠ WARNING

Do not drill or modify enclosure. Use only knockouts provided. FAILURE TO COMPLY WILL VOID WARRANTY AND MAY PRESENT A SAFETY HAZARD RESULTING IN PERSONAL INJURY, PROPERTY LOSS AND EQUIPMENT DAMAGE.

⚠ WARNING

Conduit entries must only be used for their designated purpose in order to assure safe operation and to maintain safety certification. FAILURE TO COMPLY WILL VOID WARRANTY AND MAY PRESENT A SAFETY HAZARD RESULTING IN PERSONAL INJURY, PROPERTY LOSS AND EQUIPMENT DAMAGE.

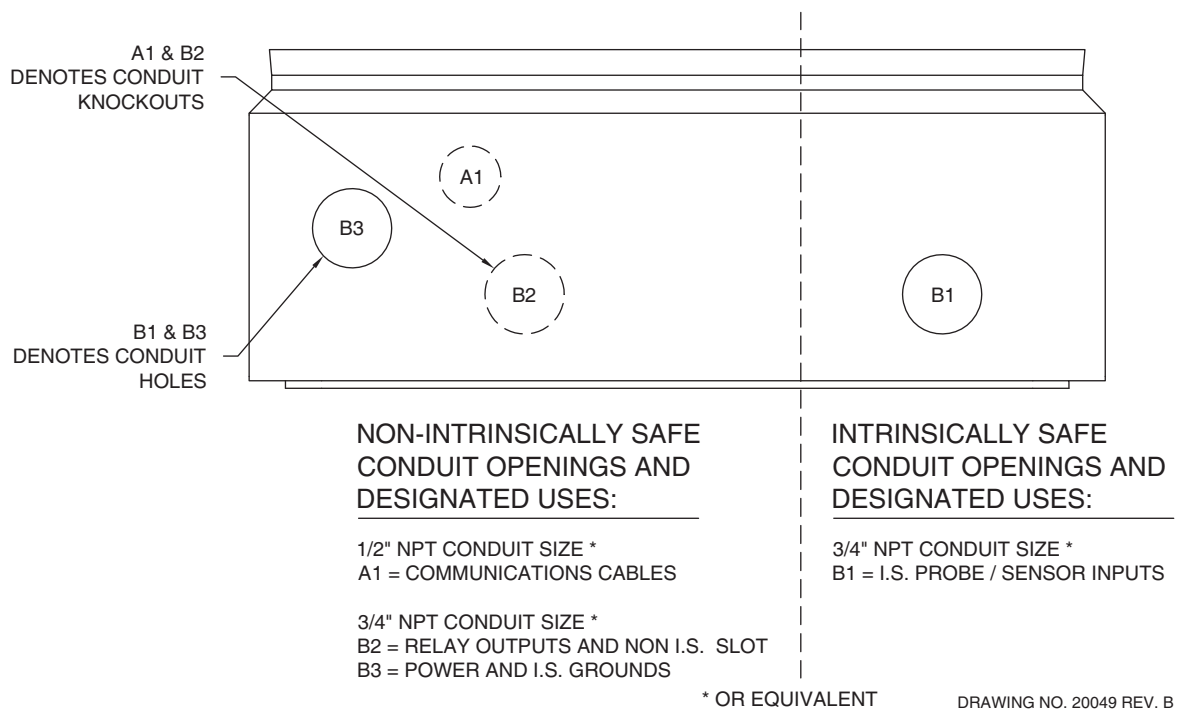

Figure 1-3 - TMS2000 Designated Conduit Locations

1.3 LIQUID LEVEL PROBE DESCRIPTION

TMS2000 can be supplied with four (4) types magnetostrictive level probes:

Model MP450S – Inventory management and EPA-compliant in-tank leak detection on Single-wall USTs.

Model MP451S – Inventory management on tanks 18’ – 24’

Model MP452S – Oil/Water separator tanks 1’ – 18’

Model MP46xS Series – Flex probe for low ceiling clearance or bulk storage tanks up to 50’

The following installation instructions cover the MP45xS Series. The MP461SC is covered in Bulletin 159 and the rest of the MP46xS Series is covered in Bulletin 171.

Figure 1-4 shows the standard MP450S probe with dimensions and specifications. Note the standard probe requires a 4-inch female NPT tank fitting, and is supplied with a 6-foot cable; it does not include the RISER CAP, which must be ordered separately. Before installing, verify the model number matches the tank size intended, and that any accessories are available on site.

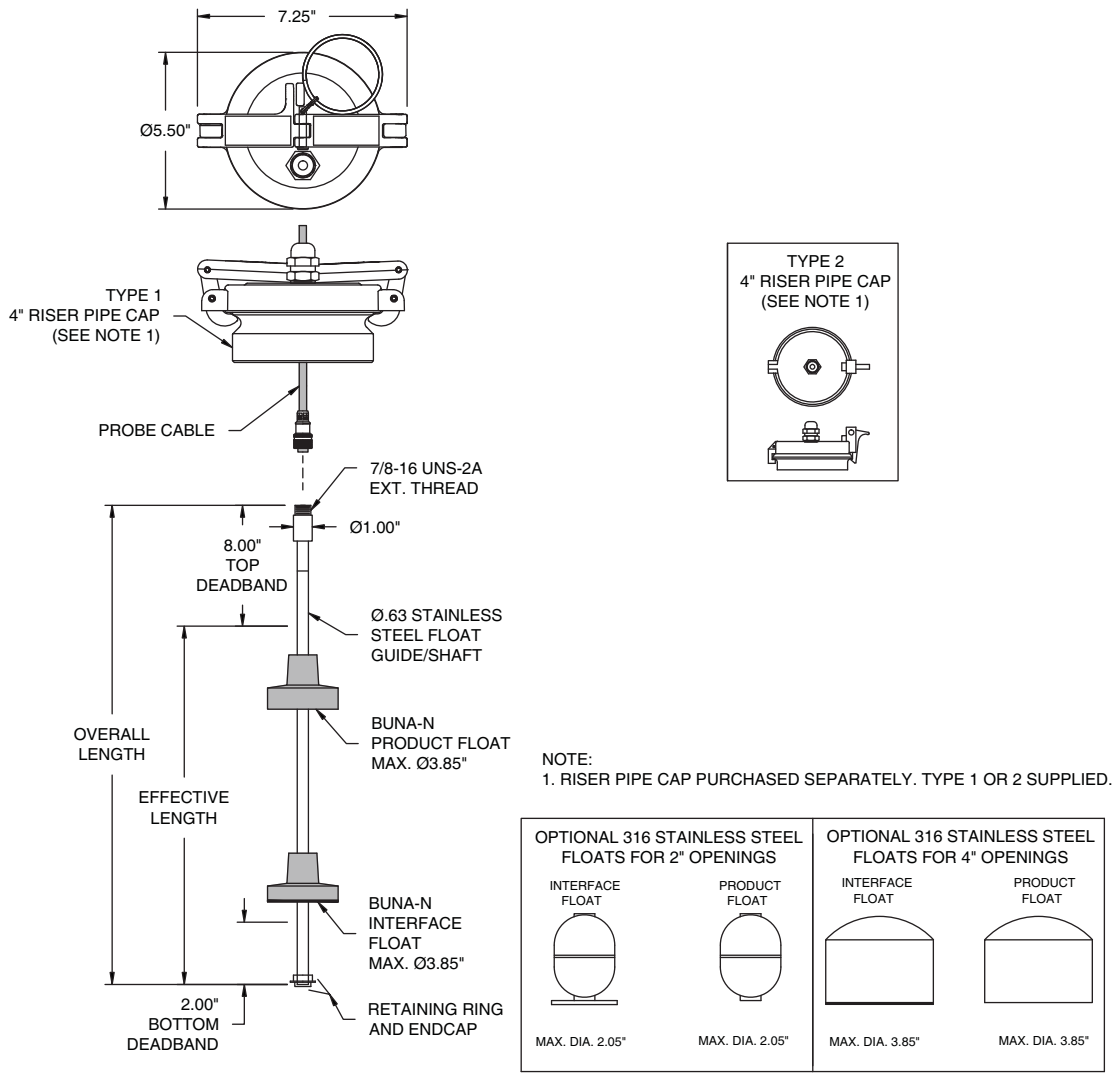

Figure 1-4 - Liquid Level Probe Outline

DRAWING NO. 20005 REV. E

1.4 LIQUID LEAK SENSOR DESCRIPTION

TMS2000 can be integrated with a variety of liquid sensors used for monitoring secondary containment areas around tanks and pipes. The maximum is 8 sensors depending on the overall job configuration; check the specific job design drawings for the actual number and type specified. Figures 1-5 through 1-8 show four (4) typical sensor types provided by Pneumercator with their most typical applications. Other non-Pneumercator models may be used; however, their use with TMS2000 should have been approved before attempting to wire them into the system.

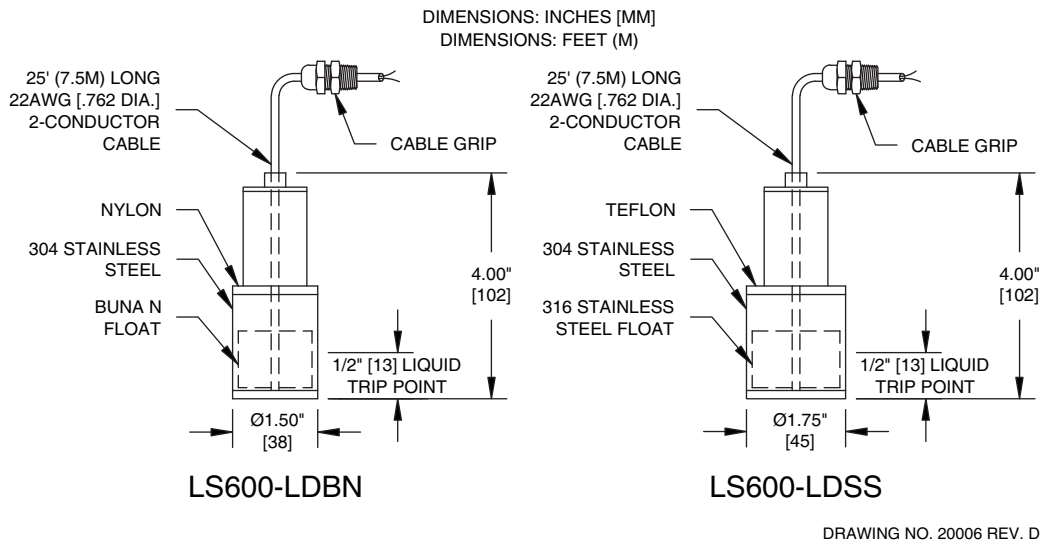

Figure 1-5 – LS600 LD Series

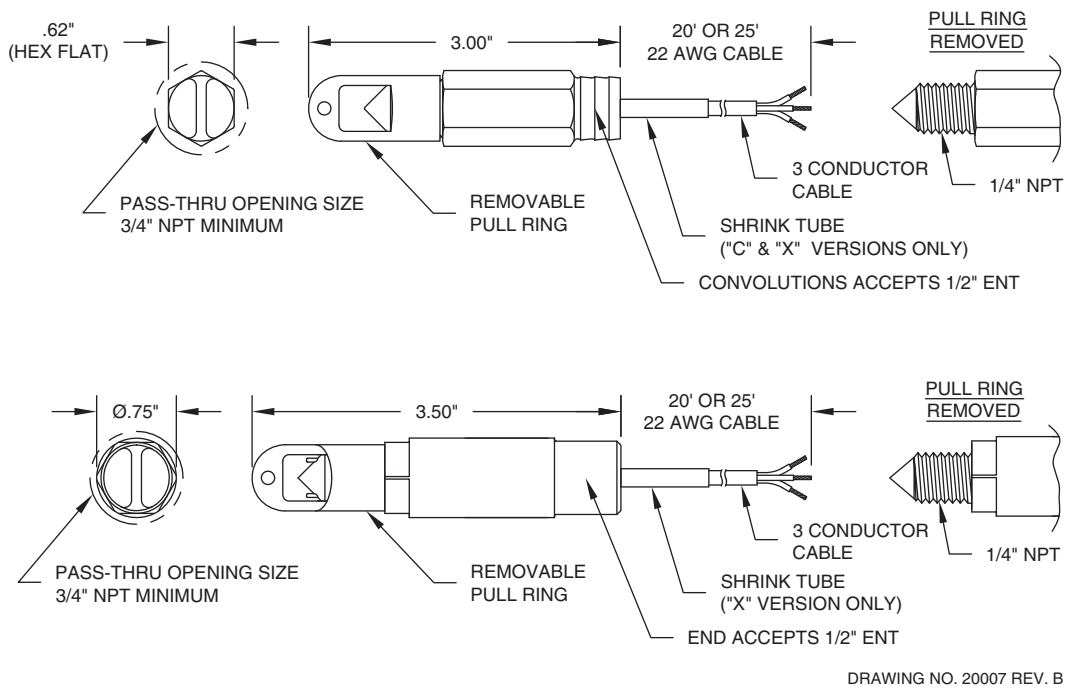

Figure 1-6 – ES825 Series

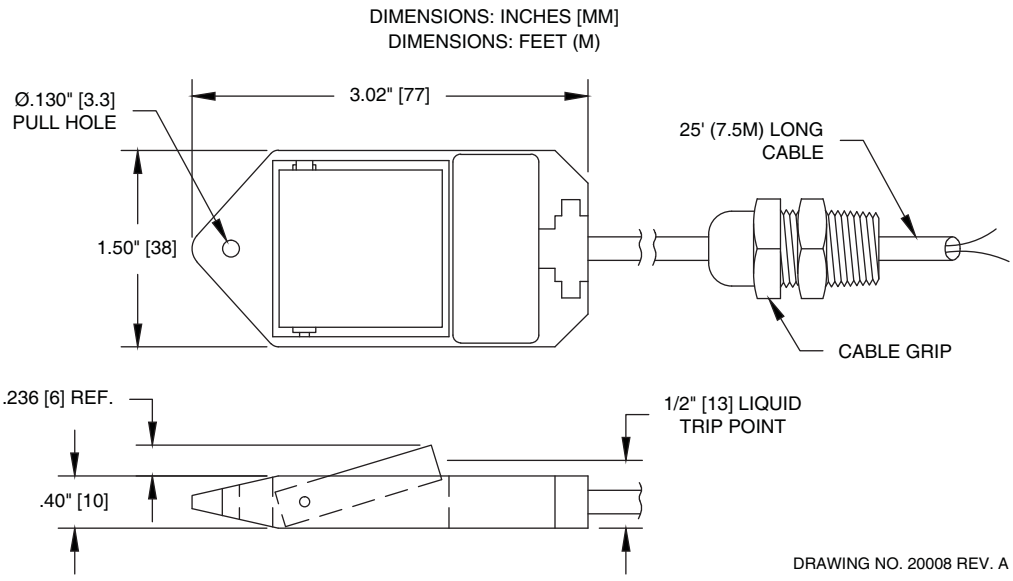

Figure 1-7 – LS610

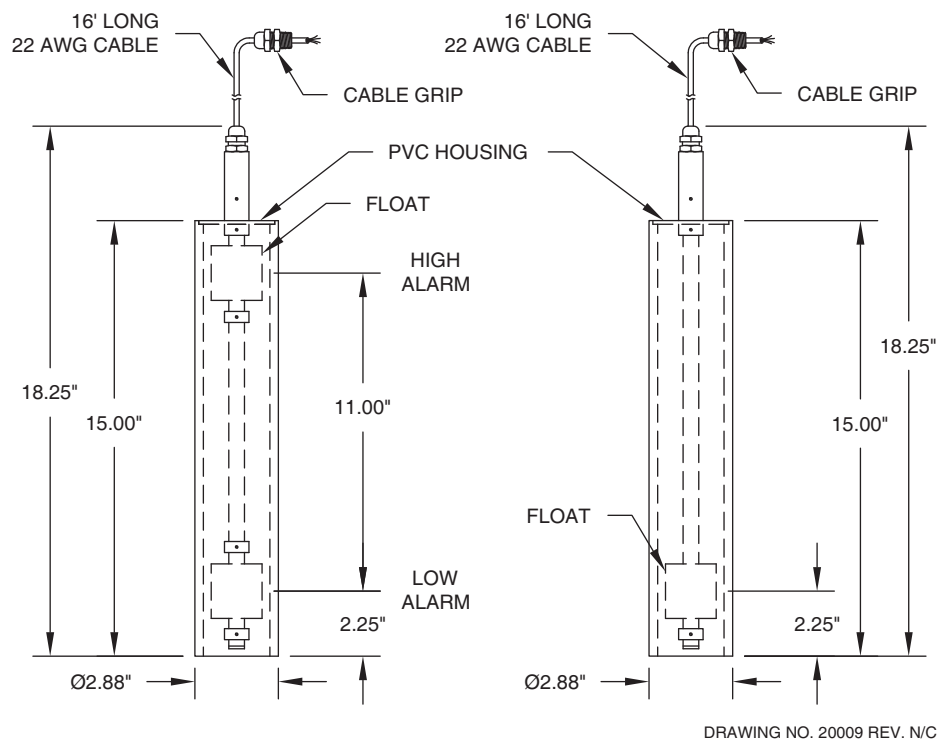

Figure 1-8 – RSU800

SECTION 2 – INSTALLATION DETAILS

2.1 INSTALLATION CHECKLIST

WARNING

Do NOT apply power to the TMS2000 until its installation has been checked and found to be in accordance with these instructions; National Electric Code; Federal, State and Local codes; and other applicable safety codes. FAILURE TO COMPLY MAY RESULT IN PERSONAL INJURY, PROPERTY LOSS AND EQUIPMENT DAMAGE.

The following points should be reviewed in preparation for installation, and again when installation is complete.

1. Review Figure 3-1 to ensure that all of the safety/wiring requirements have been met.
2. Check that all equipment at job site matches the DESIGN DRAWING SPECIFICATIONS for the tank sizes and control features required.
3. The console should be located as close as possible to the demarcation point of the hazardous area. **Never mount inside the hazardous area.**
4. POWER to the console should be properly wired to a DEDICATED 120/240 VAC CIRCUIT BREAKER. No other equipment can be powered from the same circuit breaker as the TMS.
5. System cannot be connected to equipment that uses or generates more than 250 volts with respect to earth.
6. All TMS grounds must be terminated at the GND BUSS BAR in the same service panel as TMS power. A grounding rod, coldwater pipe or other connection should not be used. Refer to Figure 3-3 for illustrated details.
7. The magnetostrictive probe inputs and the sensor inputs are two different intrinsically safe circuits and must be installed in separate cables or in one cable which has suitable insulation. Refer to NEC Article 504-30 (b) or CEC Appendix F6.3 for additional information.
8. **Do not drill or modify enclosure.** Use only knockouts provided. Failure to comply will void warranty and may present a safety hazard.
9. I.S. cabling should be selected from the Cable Selection Chart in Figure 3-2. Each probe or sensor wire/cable run SHOULD NOT EXCEED THE MAXIMUM DISTANCE RATING ON THE CABLE SELECTION CHART. Color-coding or numbering is highly recommended.
10. WATERPROOFING FIELD WIRE SPLICES using factory supplied splice kits is required for proper system operation.

2.2 CONTROL CONSOLE INSTALLATION

The console is the center of operations for any tank monitor system therefore its location should be selected for the operators convenience, or as specified on the DESIGN DRAWINGS.

Select a flat wall surface and prepare it with four wall-mounting inserts to accept up to 1/4-inch size bolts. Allow sufficient room for door to open and for conduit runs to enter **ONLY THE CONSOLE BOTTOM**. See Figure 1-2 for console dimensions.

Note that the console is divided into two electrical areas:

NON INTRINSICALLY SAFE (LEFT SIDE)
for Power and Control

INTRINSICALLY SAFE (RIGHT SIDE)
for Probe/Sensor signals

Figure 2-1 shows the console interior, again indicating the power and signal separation. **THIS SEPARATION MUST BE MAINTAINED** when conduits are connected. Refer to Section 3 for electrical conduit and wiring.

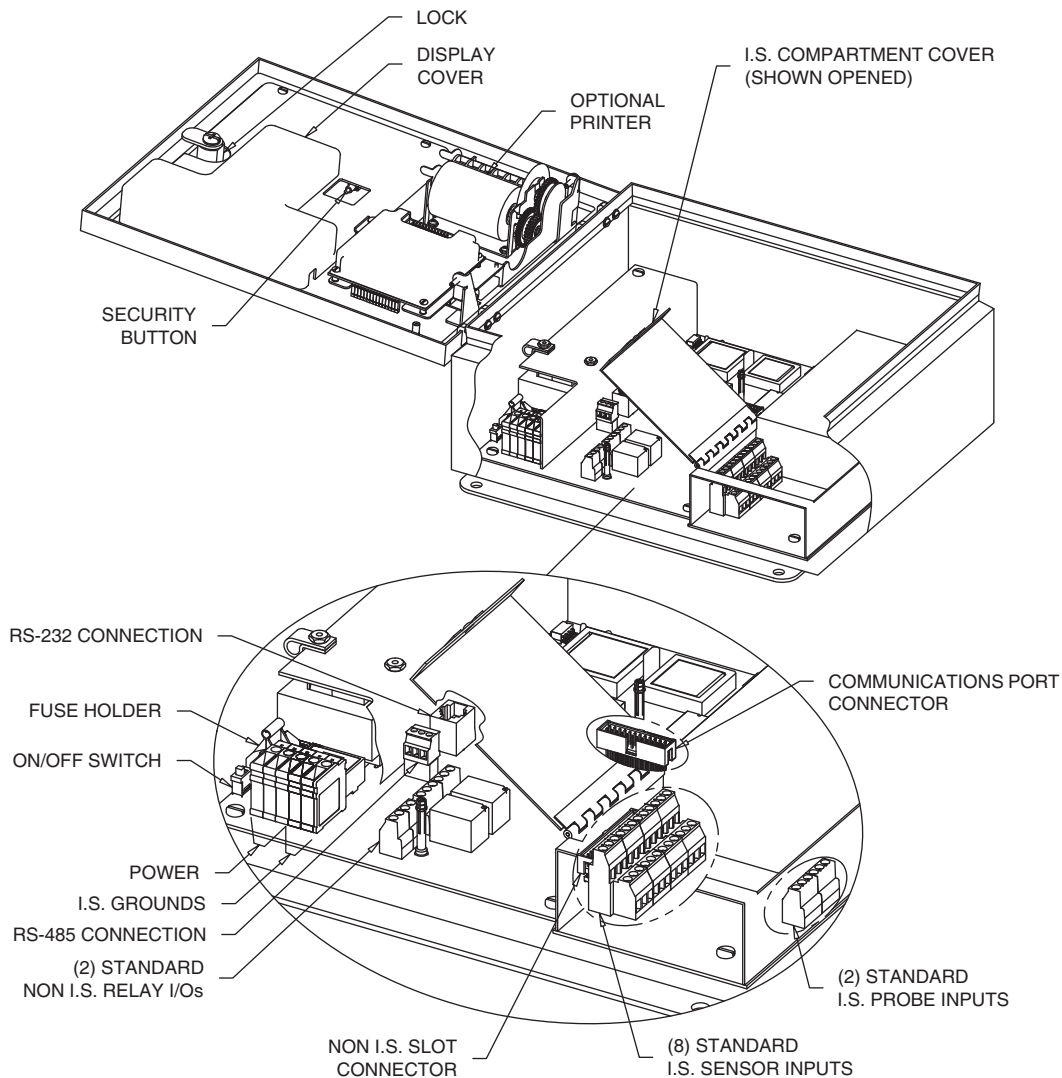

DRAWING NO. 20050 REV. A

Figure 2-1 - Control Console Interior

2.3 LEVEL PROBE INSTALLATION IN UNDERGROUND TANKS

Installing the magnetostrictive level probe underground is similar for both STEEL and FIBERGLASS tanks. Refer to Figure 2-2. The tank top must be equipped with an access MANHOLE containing a probe RISER PIPE and WATERTIGHT ELECTRICAL JUNCTION BOX supplied by the installer; the junction box should be sized to handle ONLY PROBE AND MANHOLE LEAK SENSOR cable splices for wiring to the console. The manhole should be at least 18 inches in diameter and a height suitable for the tank burial depth. The riser should be 4-inch pipe opening (2 and 3-inch for optionally available probes). The riser top should be fitted with a schedule 40 RISER PIPE cut to length to provide the minimum height of 18 inches shown measured from the TANK TOP (ID) to the probe's RISER CAP. The level probe's electronic housing will reside "inside" the riser. The riser top should be NPT male threaded and allow a clearance of at least 6 inches to the underside of the manhole cover. This will provide enough space for the riser cap and probe cable. For riser caps not supplied by Pneumercator, the cap must have a 1/2-inch NPT tapped hole for probe cable passage.

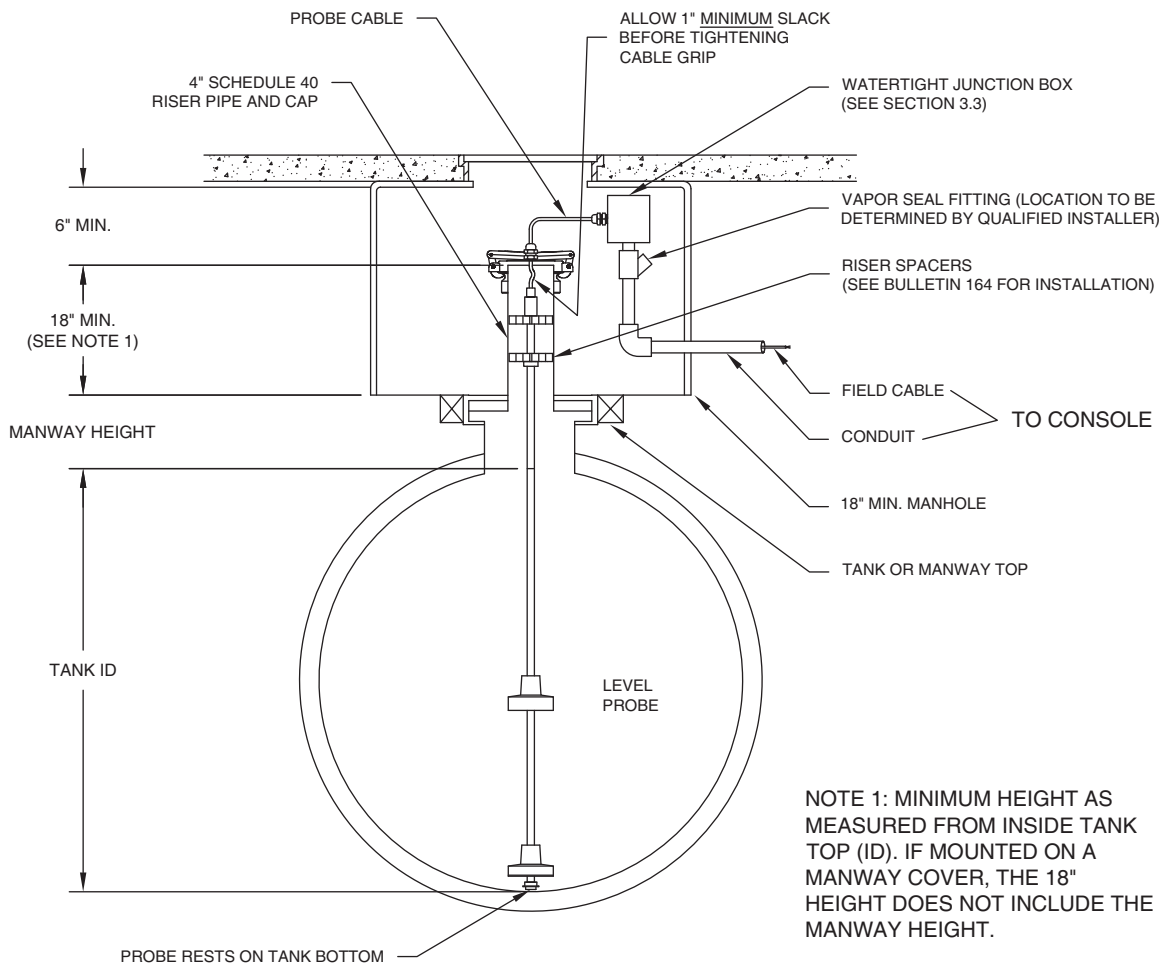

Figure 2-2 - Level Probe Installation - Underground Tank

ASSEMBLY INSTRUCTIONS - RISER MOUNTED MODEL:

MP42xS	
MP45xS	MP55xS

IMPORTANT! ALL of the following requirements must be met;

- Probe length does not exceed 15 feet.
- Tank **does not** contain chemicals, solvents or heated products where standard PVC leader cable is used.
- Tank **does** contain chemical, solvent or heated products where chemical/heat resistant probe assembly and leader cable are used and confirmed to be compatible with stored product.
- Tank is not pressurized.

Questions? Contact Technical Support at (800) 209-7858

FOR INSTALLATION AND WIRING SEE TMS MANUAL

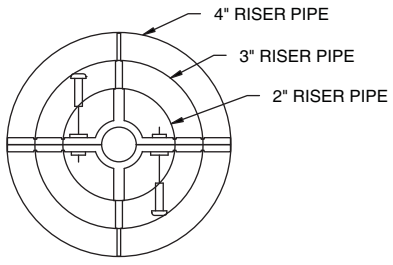
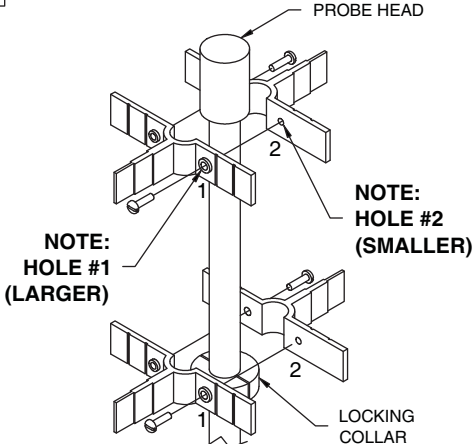
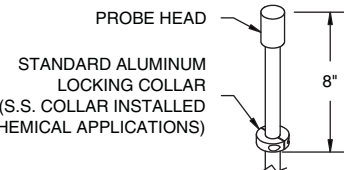
<p>1 Trim spacers for the desired <u>schedule 40</u> riser pipe diameter.</p> 	<p>3 Assemble riser spacers.</p>  <p>NOTE: AT THIS POINT MODEL MP452S ASSEMBLY IS COMPLETE. PROCEED TO STEP 4 TO COMPLETE ASSEMBLY FOR ALL OTHER MODELS.</p>
<p>2 Verify that the bottom of the locking collar is located 8" from the top of the probe head and confirm that collar is secured.</p>  <p>STANDARD ALUMINUM LOCKING COLLAR (S.S. COLLAR INSTALLED FOR CHEMICAL APPLICATIONS)</p>	

<p>4 4" RISER MOUNTING ASSEMBLY</p> <p style="text-align: center;"><u>STANDARD APPLICATIONS</u></p> 	<p style="text-align: center;"><u>STANDARD APPLICATIONS</u></p> <p style="text-align: center;">WITH INTERFACE * WITHOUT INTERFACE</p> 	<p style="text-align: center;"><u>CHEMICAL APPLICATIONS</u></p> <p style="text-align: center;">WITH INTERFACE * WITHOUT INTERFACE</p>  <p style="text-align: center;">* NOT APPLICABLE FOR MP42xS</p>
--	--	---



Figure 2-3 - MP45xS Probe Assembly Instructions - Riser Mount

Install the level probe in the UNDERGROUND TANK as follows:

1. Select the correct probes for the tank. Match the model number with tank internal dimensions per Figure 1-4.
2. Assemble the probe per Bulletin 164 shown in Figure 2-3.
3. Slowly lower probe into tank opening until probe's FOOT REST is on the tank bottom. The probe should be vertical with both centering spacers totally supported within the riser pipe.
4. Feed the probe cable through the underside of the riser cap cord grip supplied. Keep the grip loose so cable can be flexed. Leave enough slack beneath the cap so the probe rests on the tank bottom, and above the cap to reach the electrical junction box in the manhole.
5. Prepare riser pipe and cap with pipe dope or suitable compound, and carefully mate them together.
6. Tighten the cable cord grip on top of the riser cap to ensure a WATERTIGHT SEAL.
7. Route the probe cable to the manhole junction box and complete the electrical installation in accordance with Section 3.

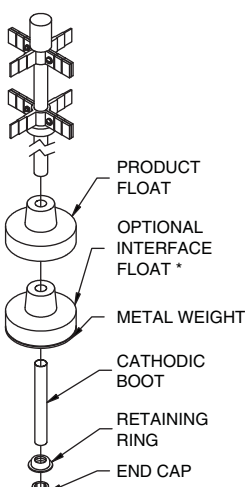
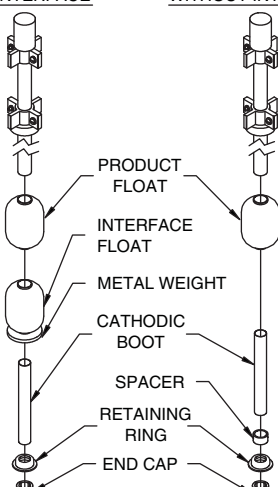
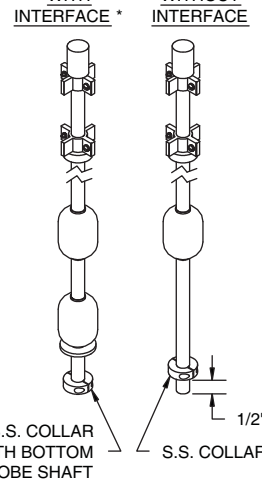
2.4 LEVEL PROBE INSTALLATION IN ABOVEGROUND TANKS

NOTE: For tanks located inside buildings or vaults, or under outdoor containment shelters:

Rigid Level Probes models MP450S, MP451S, & MP452S require tank headroom clearance at least equal to overall probe length for insertion and removal. See Figure 1-4 for probe dimensions.

There are two methods of installing the level probe in aboveground tanks shown in Figures 2-4 and 2-5. The choice is dictated by the actual fitting supplied integral to the probe.

The standard method shown in Figure 2-4 uses a RISER PIPE mounted on top of the tank to support the probe; similar to an underground tank installation. The optional method shown in Figure 2-5 employs a REDUCER FITTING to support the probe.

Risers and reducers are SUPPLIED BY THE INSTALLER.

2.4.1 RISER PIPE METHOD FOR ABOVE GROUND TANKS

Tank openings must be fitted with a schedule 40 RISER PIPE cut to length to provide the minimum height of 18 inches shown measured from the TANK TOP to the probe's RISER CAP. Both of the level probe's centering spacers will reside "inside" the riser.

The riser top should be NPT male threaded and allow a clearance of at least 6 inches to the underside of any roof cover that may be added after probe installation. This will provide enough space for the riser cap and probe cable. For riser caps not supplied by Pneumercator, the cap must have a 1/2-inch NPT tapped hole for probe cable passage.

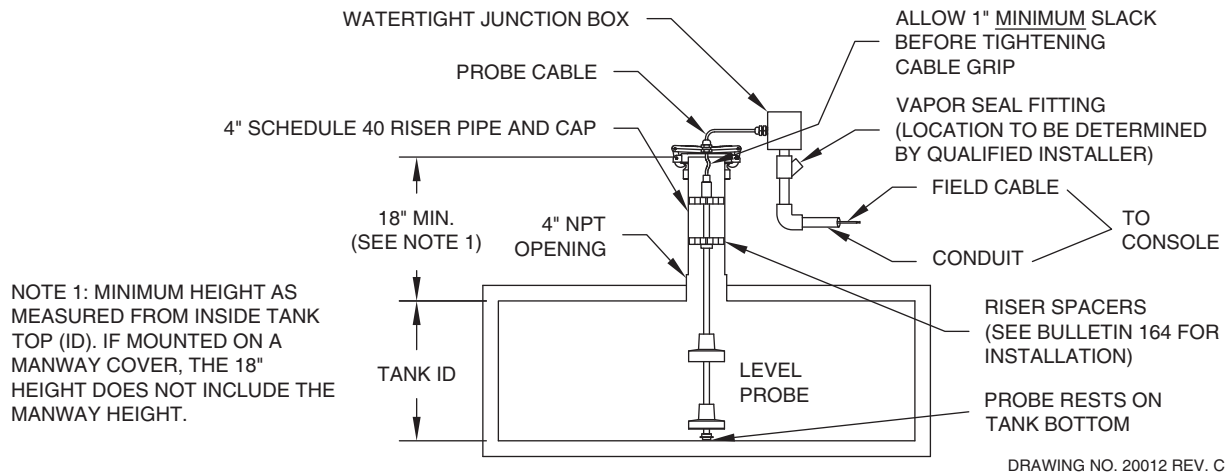

Figure 2-4 - Riser Pipe Mounting Aboveground Tanks

Install the level probe per Figure 2-4 as follows:

1. Select the correct probe for the tank. Match the model number with tank internal dimensions per Figure 1-4.
2. Assemble the probe per Bulletin 164 shown in Figure 2-3.
3. Slowly lower probe into tank opening until probe's FOOTREST is on the tank bottom. The probe should be vertical with both centering spacers totally supported within the riser pipe.
4. Feed probe cable through the underside of the riser cap cord grip supplied. Keep the grip loose so cable can be flexed. Leave enough slack beneath the cap so the probe rests on the tank bottom, and above the cap to reach the electrical junction box.
5. Prepare riser pipe and cap with pipe dope or suitable compound, and carefully mate them together.
6. Tighten the cable cord grip on top of the riser cap to ensure a WATERTIGHT SEAL.
7. Route the probe cable to the junction box and complete the wiring installation in accordance with Section 3.

2.4.2 BUSHING OR FLANGE MOUNT METHOD FOR ABOVE GROUND TANKS

This method is employed for large vertical tanks and heated, pressurized, or chemical applications but may also be used for standard 2, 3 and 4-inch openings when it is not desired to enclose the electronic housing within a pipe riser. The level probe will "hang" inside the tank at a fixed position supported by the tank-mounting fitting.

Because the probe is fixed to the mounting fitting, it is critical during installation to allow a 1-INCH BOTTOM CLEARANCE between the probe's FOOT REST and tank bottom or strike plate. This will prevent the probe touching the tank bottom during tank expansion and contraction. The 1-inch clearance dimension is standard and has been properly accounted for in the probe's manufacture.

The customer must supply an appropriate mounting fitting to mate with the tank opening, if less than 2 inches, to accommodate the PK2-DM Direct Mount Probe Kit. Assembly is as illustrated in Figure 2-6.

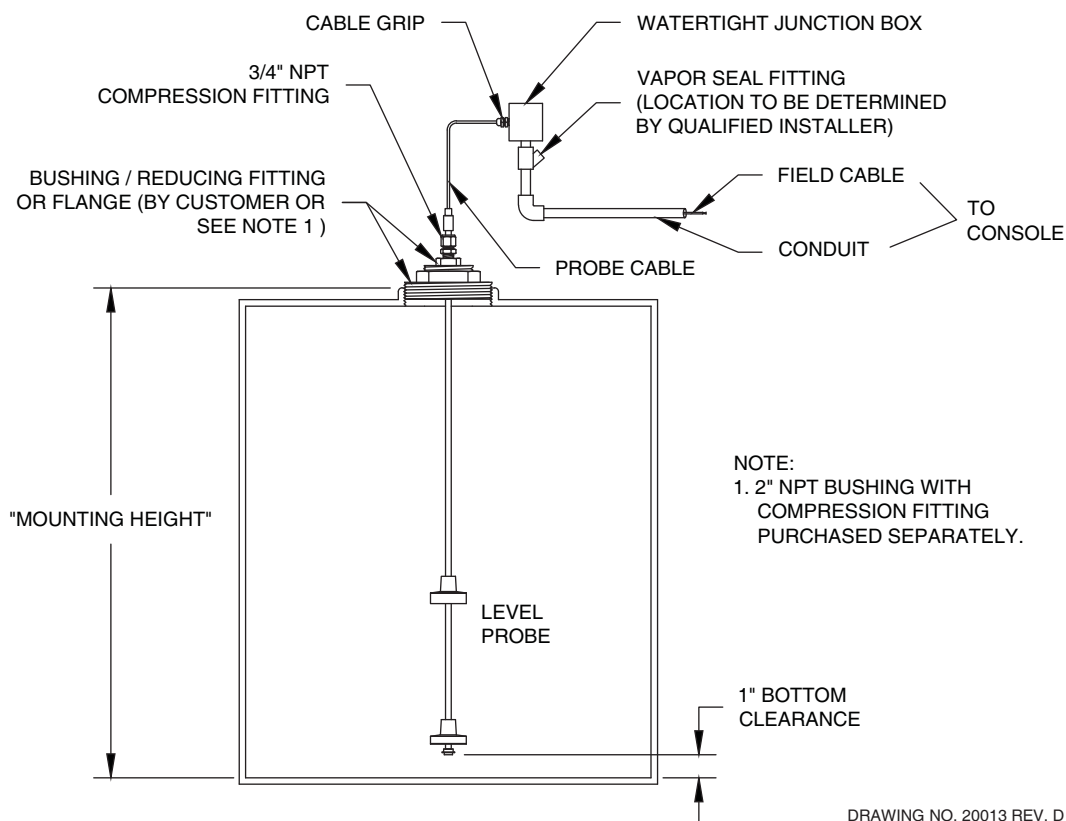

Figure 2-5 - Reducer Fitting or Flange Mounting for Aboveground Tanks

Install the level probe per Figure 2-5 as follows:

1. Select the correct probe for the tank. Match the model number with the tank internal dimensions per Figure 1-4.
2. Remove the probe from its shipping container. Remove all packing material.
3. Slowly lower the probe into tank opening. The probe should be vertical with its electronic housing totally visible above the tank fitting. When the probe touches the bottom, screw the bushing into the tank. DO NOT tighten the compression fitting at this time. Mark the shaft and lift the probe up 1 INCH.

ASSEMBLY INSTRUCTIONS - DIRECT MOUNTED MODEL:

MP42xS	
MP45xS	MP55xS

Applies to the following installations;

- Probe lengths exceeding 15 feet.
- Chemical, solvent or heated tanks using standard PVC leader cable.
- Pressurized tanks. Consult with Technical Support for pressure limits.

Questions? Contact Technical Support at (800) 209-7858

FOR INSTALLATION AND WIRING SEE TMS MANUAL

- 1** The top of the probe is an unengageable deadband. Verify that the probe is of sufficient length so that the float's magnet will not travel into this deadband.

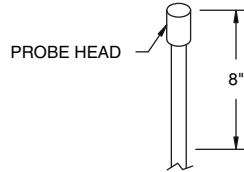

2 4" DIRECT MOUNTING ASSEMBLY

2" DIRECT MOUNTING ASSEMBLY

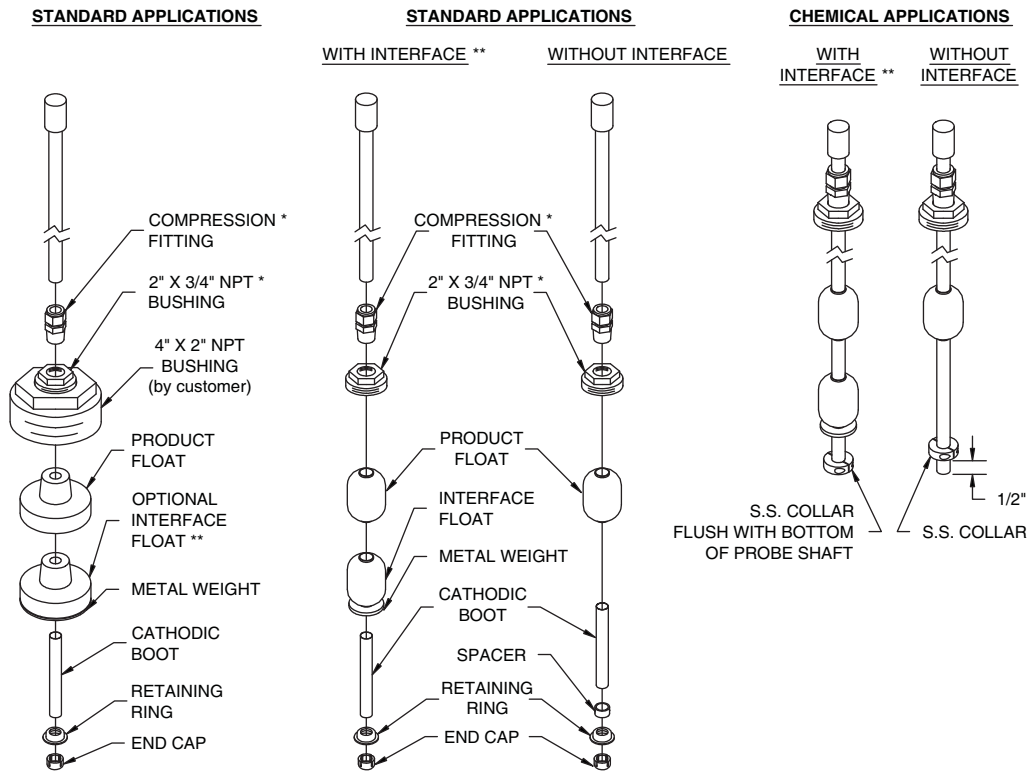

* PURCHASED SEPARATELY FROM PNEUMERCATOR AS MODEL NO. PK2-DMx.
 ** NOT APPLICABLE FOR MP42xS



Figure 2-6 - MP45xS Probe Assembly Instructions - Direct Mount

4. Tighten the cable connector on top of the probe housing to ensure a WATERTIGHT SEAL.
5. Route the probe cable to the junction box and complete the wiring installation in accordance with Section 3

EXTERNAL LEAK SENSOR INSTALLATION

The interstitial or double-wall space of steel tanks and vaulted tanks as well as many other secondary containment areas can be fitted with either DISCRIMINATING or NON-DISCRIMINATING leak sensors. Also, for float type non-discriminating sensors, switch actuation may be factory set for either NORMALLY OPEN or NORMALLY CLOSED.

2.5 LEAK SENSOR INSTALLATION IN STEEL AND VAULTED TANKS

Check the specific design drawings for the job, or choose the sensor type desired from Figures 1-5 and 1-6. Install sensor per Figure 2-7 as follows:

1. Remove the watertight CORD CONNECTOR supplied by sliding it off the sensor cable.
2. Thread the watertight CONNECTOR into the top of a 2" by 1/2" reducer bushing or monitor pipe cap pre-tapped for a 1/2" NPT hole. (The use of any standard monitor cap from 2" to 4" pipe size is recommended. The cap or reducer bushing IS NOT SUPPLIED with the sensor and must be provided by the installer).
3. Measure the "MOUNTING HEIGHT" from top to bottom of monitoring pipe.
4. Feed the sensor cable through the watertight CONNECTOR from the BOTTOM SIDE of the REDUCER (or CAP) fitting to a cable length suitable for the MOUNTING HEIGHT; or to allow sensor to rest on the monitor pipe bottom; or as required by local codes. Cable may be cut or extended to proper length.
5. Re-tighten the CORD CONNECTOR to fix the sensor cable length.
6. Mate the REDUCER or CAP to the top of the monitor pipe. Tighten the CONNECTOR to ensure a WATERTIGHT SEAL.
7. Route the sensor cable to the junction box and complete the wiring installation in accordance with Section 3.

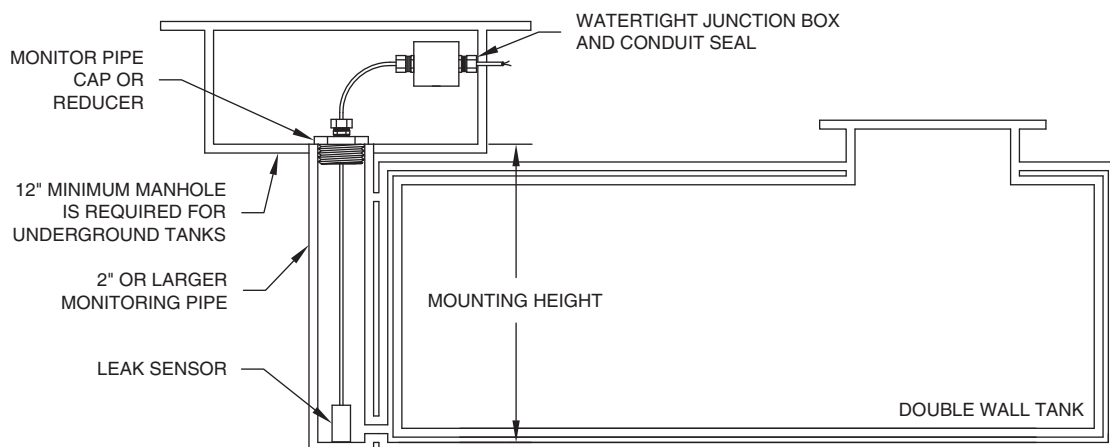

DRAWING NO. 20016 REV. C

Figure 2-7 - Leak Sensor Installation - Steel Vaulted Tanks

2.6 LEAK SENSOR INSTALLATION IN PIPING SUMPS AND DISPENSER PANS

Check the specific design drawings for the job, or choose the sensor type desired from Figures 1-5 and 1-6. Install sensor per Figure 2-8 as follows:

1. Measure the "MOUNTING HEIGHT" from conduit or junction box to the bottom of the SUMP (or MANHOLE, VAULT or DISPENSER PAN).
2. Feed the sensor cable through the watertight CONNECTOR to length suitable for the MOUNTING HEIGHT; or to allow sensor to rest on the containment bottom; or as required by local codes. Feed an additional 12 inches past the CONNECTOR for splicing inside the junction box; cable may be cut to proper length.
3. Thread the CONNECTOR into the WATERTIGHT JUNCTION BOX and tighten the CONNECTOR cord grip over the cable to insure a WATERTIGHT SEAL. The sensor should rest on the containment floor or as required by local codes.
4. Complete the wiring installation in accordance with Section 3.

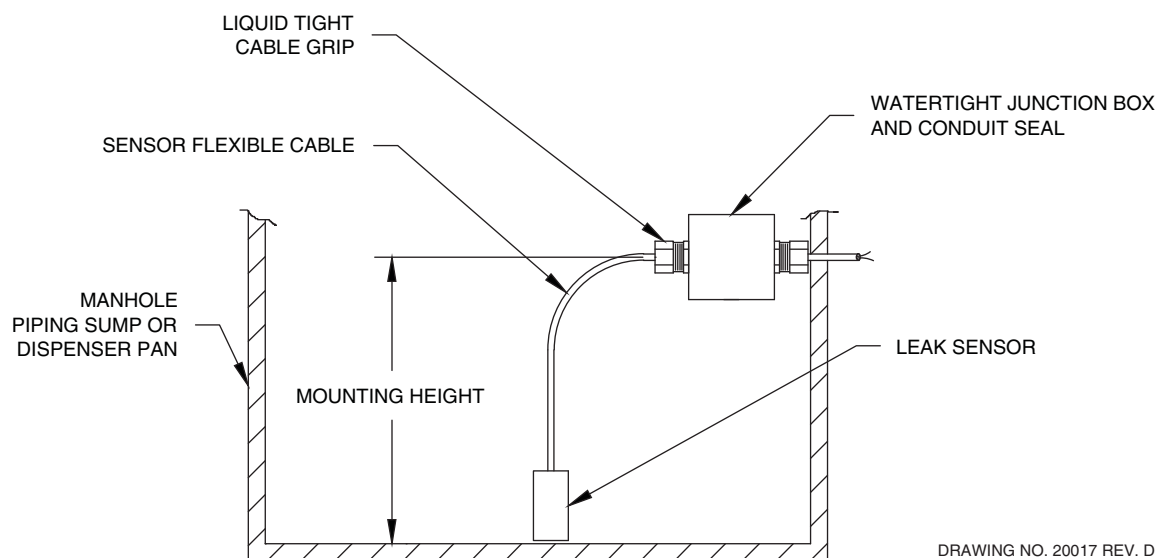

Figure 2-8 - Leak Sensor Installation in Piping Sumps, Manholes, and Dispenser Pans

2.7 LEAK SENSOR INSTALLATION IN FIBERGLASS TANK ANNULUS

The annular space of fiberglass tanks can be fitted with either a "DRY ANNULUS" type sensor, models ES825 (Figure 1-6) and LS610 (Figure 1-7), or a "WET RESERVOIR" sensor model RSU800 (Figure 1-8). The wet reservoir is also referred to as the HYDROSTATIC METHOD. Check the specific design drawings for the job, or choose the type sensor desired from Figures 1-6 through 1-8. Install sensor per Figures 2-9 or 2-10.

Instructions per Figure 2-9, DRY ANNULUS SENSOR:

1. Calculate the sensor cable's MOUNTING LENGTH from tank size data so the sensor rests at tank bottom; or use the following method.

Determine the cable's MOUNTING LENGTH by adding the cable measurement M from the table at the right to the RISER HEIGHT. Mark the cable at that length. **DO NOT CUT THE CABLE.**

2. Remove the watertight CORD CONNECTOR supplied by sliding it off the cable.
3. Thread the CONNECTOR into the top of a 2" by 1/2" reducer bushing or riser pipe cap pre-tapped for a 1/2" NPT hole. (The use of any standard monitor cap from 2" to 4" pipe size is recommended. The cap or reducer bushing IS NOT SUPPLIED with the sensor and must be provided by the installer).
4. At riser top, attach the annular space PULL CORD (this is part of the tank supplier's pre-installed accessories) to the sensor's PULL HOLE.
5. Pull the free end of the PULL CORD out of the riser while feeding the sensor into the riser and through the annular space until the sensor is at the bottom centerline of the tank. The MOUNTING LENGTH MARK should be about 5 INCHES above the open riser. Adjust its position as necessary and, without disconnecting the PULL CORD, coil its excess inside the riser pipe.
6. Feed the sensor cable through the BOTTOM of the riser cap (or bushing), and through the CORD CONNECTOR while positioning cap over the riser pipe. Mate riser and cap.
7. Tighten CONNECTOR over the cable to ensure a WATERTIGHT SEAL.
8. Complete the wiring installation in accordance with Section 3.

CABLE MEASUREMENT FROM END OF SENSOR

Tank Dia.	Cable M
4 Feet	81 in.
6 Feet	118 in.
8 Feet	150 in.
10 Feet	194 in.
12 Feet	222 in.

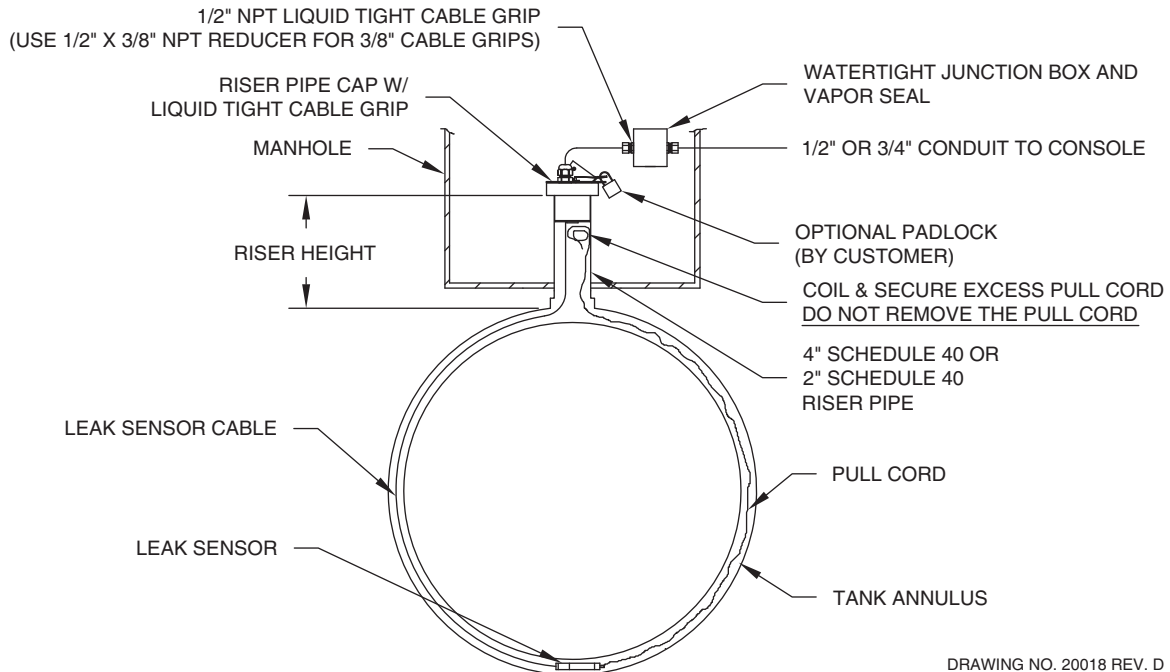

DRAWING NO. 20018 REV. D

Figure 2-9 - Dry Leak Sensor Installation in Fiberglass Tanks

2.8 HYDROSTATIC LEAK SENSOR INSTALLATION IN FIBERGLASS TANK RESERVOIRS

The model RSU800 sensor uses a dual float that senses a HIGH and LOW liquid level within the reservoir. If a tank leak occurs through either wall of the DOUBLE-WALL tank the liquid level in the reservoir changes. When it reaches the upper or lower limits of the sensor a contact closure is transmitted to the control console.

Instructions per Figure 2-10, HYDROSTATIC LEAK SENSOR:

1. The tank reservoir should be fitted with a 4 inch RISER PIPE and CAP, supplied by THE INSTALLER. The riser should be at least 12 inches long as measured from the reservoir opening. The riser cap may be any standard type, but as a minimum it should have a 3/8" NPT tapped hole to accept the CORD GRIP CONNECTOR SUPPLIED BY PNEUMERCATOR, or contain its own suitable cord grip. (An alternate method is to drill and tap the wall of the riser pipe). The use of a riser cap with a VENT TUBE is only recommended where local installation requires one.
2. If the riser cap does not contain its own cord connector, thread the PNEUMERCATOR SUPPLIED CONNECTOR into the tapped hole using sealing compound as required. (Alternately, the CONNECTOR may be threaded into the sidewall of the riser).
3. Slowly lower the sensor into the riser until it rests on the reservoir bottom. The top portion should extend into the riser pipe for support from tipping over. The liquid level in the reservoir should be at about 7 inches up the sensor's height for optimum performance. (See Figure 1-8 for float travel set point limits).

4. Feed the sensor cable through the BOTTOM of the riser cap (or pipe wall), and through the CORD CONNECTOR. Leave just enough slack inside the riser pipe so the sensor remains on the bottom, and will not tip over.
5. Mate the riser and cap; tighten the CONNECTOR over the cable to ensure a WATERTIGHT SEAL.
6. Complete the wiring installation in accordance with Section 3.

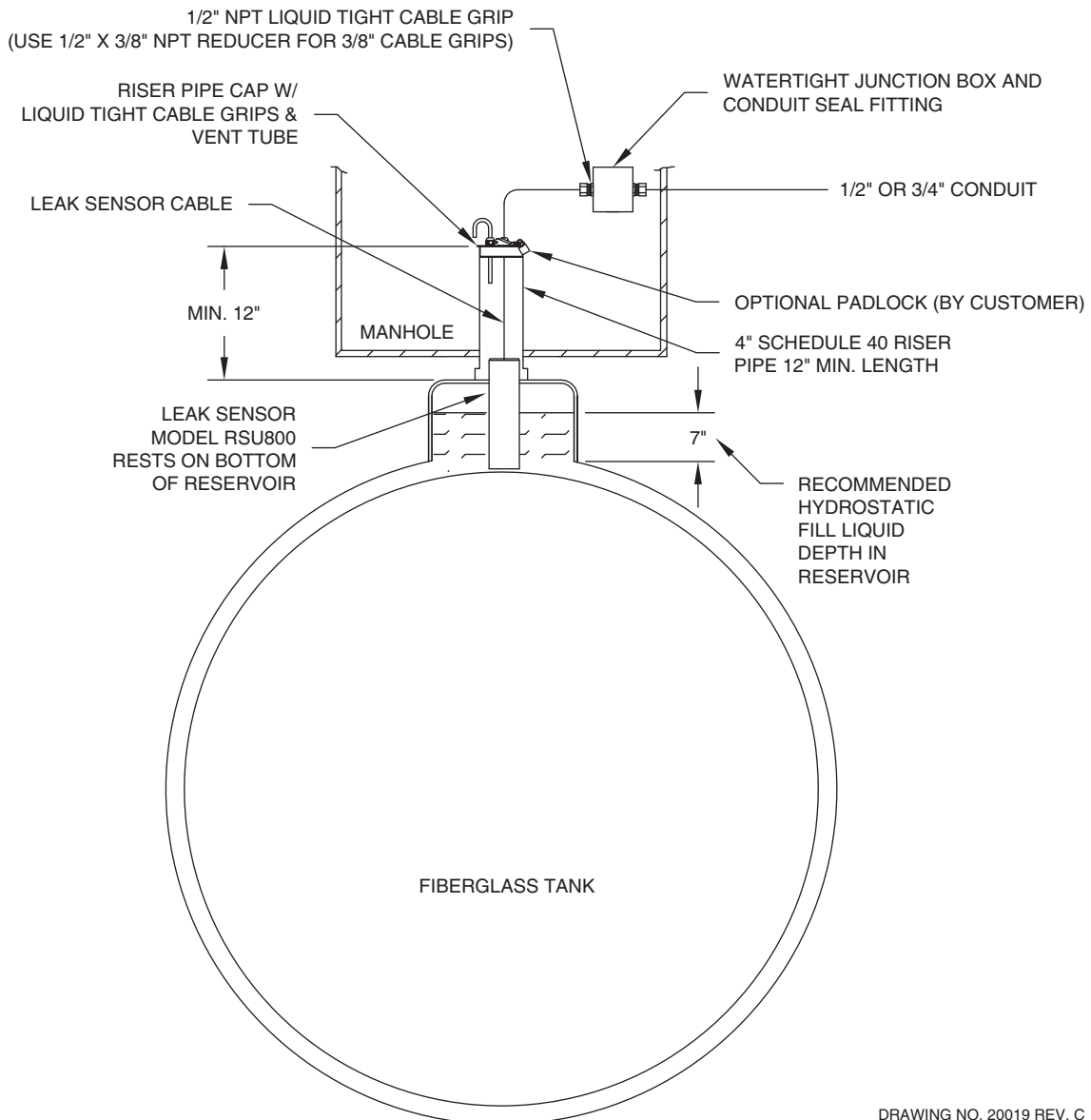

Figure 2-10 - Hydrostatic Leak Sensor Installation in Fiberglass Tanks

DRAWING NO. 20019 REV. C

SECTION 3 WIRING INSTALLATION AND DIAGRAMS

⚠ CAUTION

Liquid level probes and leak sensors connected to the TMS2000 are usually installed in explosion hazard areas typical of hydrocarbon fuel tanks. For these applications, it is CRITICAL that electrical conduit and wiring be installed by qualified installers familiar with all provisions of the National Electrical Code relating to equipment intended for use in EXPLOSION HAZARD areas. The primary concern is to maintain physical separation between intrinsically safe and non-intrinsically safe wiring by running separate conduit attached to the control console at the designated knockouts. ALL conduits carrying probe and sensor wiring into the hazardous area MUST be fitted with standard vapor seal-off fittings at all field junction boxes and again where the conduit first enters the non-hazardous area. FAILURE TO COMPLY MAY RESULT IN PERSONAL INJURY, PROPERTY LOSS AND EQUIPMENT DAMAGE.

3.1 SYSTEM INTRINSIC SAFETY WIRING

Figure 3-1 is a typical System Wiring Diagram that must be followed when running conduit and wires between the HAZARDOUS TANK area and the NON-HAZARDOUS CONSOLE area. This follows UL and other codes for proper installation.

PROBE AND SENSOR WIRING INSTALLATION. Refer to Figures 1-3 through 1-8 for console conduit openings and specific probes/sensors that will be wired into the TMS2000 system. Install wiring as follows:

1. Install 3/4" rigid conduit from all probe and sensor areas to the TMS2000 console.

⚠ CAUTION

All probe and sensor wiring from the TMS2000 console may be run in the same conduit. NO OTHER WIRING MAY BE RUN IN THESE CONDUITS. NEVER RUN POWER WIRES IN THESE CONDUITS. FAILURE TO COMPLY MAY RESULT IN PERSONAL INJURY, PROPERTY LOSS AND EQUIPMENT DAMAGE.

2. At appropriate locations along the conduit runs (see Figures 2-2, 2-4, 2-5 through 2-10) install watertight couplings and approved VAPOR SEAL-OFF fittings.
3. At each probe/sensor location, install a WATERTIGHT ELECTRICAL JUNCTION BOX. Allow enough room around the probe/sensor tank fitting for proper installation of the probe/sensor and all conduit/junction box fittings, and for later removal if necessary.
4. Attach the conduit at the TMS2000 console ONLY to the 3/4" conduit knockout located on the bottom RIGHT SIDE. Use NEMA 4 fittings for outdoor locations.

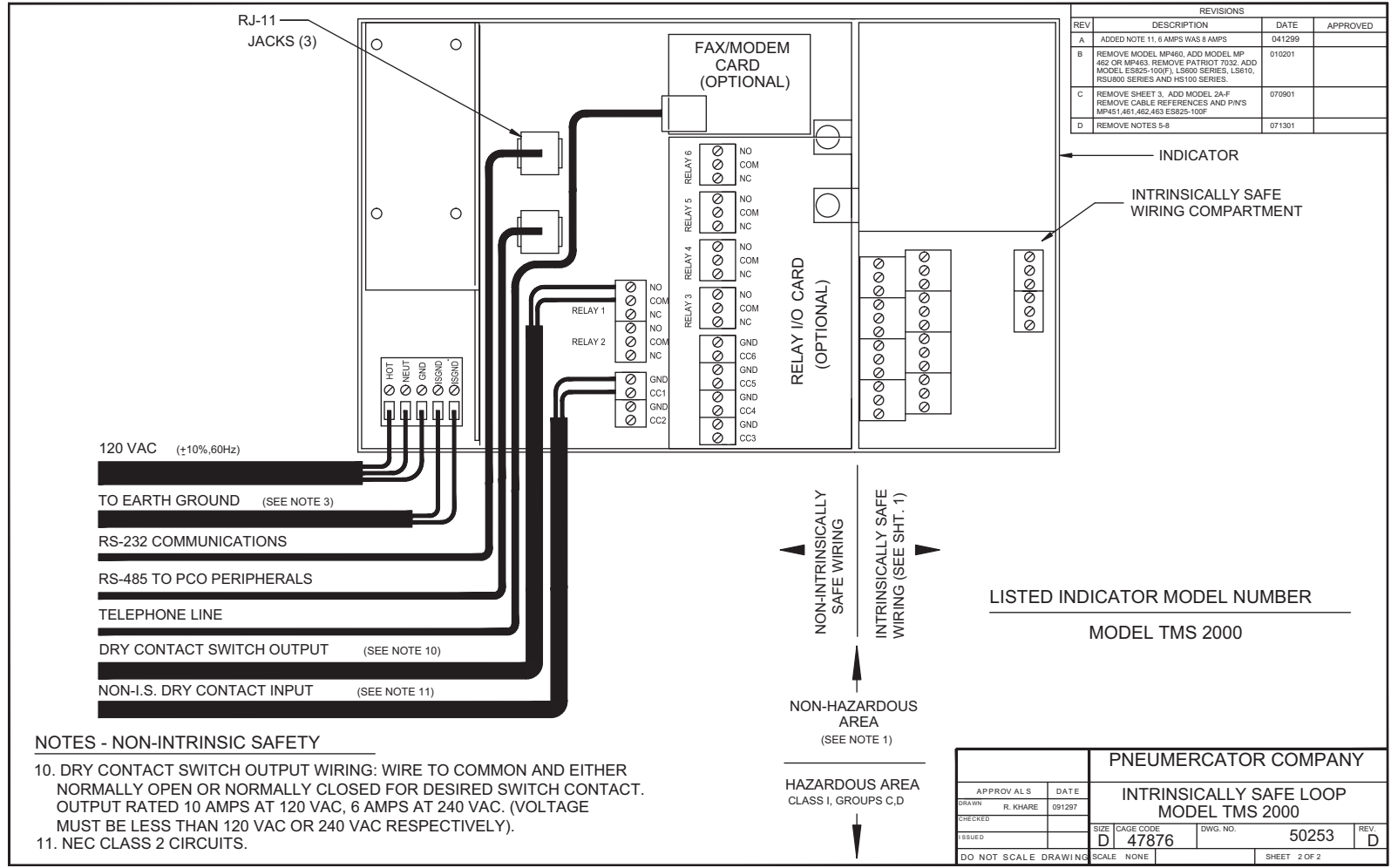

REVISIONS			
REV	DESCRIPTION	DATE	APPROVED
A	ADDED NOTE 11, 6 AMPS WAS 8 AMPS	041299	
B	REMOVE MODEL MP460, ADD MODEL MP 462 OR MP463; REMOVE PATRIOT 7032, ADD MODEL ES825-100(F), LS600 SERIES, LS610, RS3800 SERIES AND HS100 SERIES.	010201	
C	REMOVE SHEET 3, ADD MODEL 2A-F REMOVE CABLE REFERENCES AND PINS MP451,461,462,463 ES825-100F	070901	
D	REMOVE NOTES 5-8	071301	

PNEUMERCATOR COMPANY			
INTRINSICALLY SAFE LOOP MODEL TMS 2000			
APPROVALS	DATE	SIZE	REV.
DRAWN R. KHARE	091297	D	D
CHECKED		CAGE CODE	DWG. NO.
ISSUED		47876	50253
DO NOT SCALE DRAWING		SCALE	SHEET 2 OF 2
		NONE	

Figure 3-1b - Non-Hazardous Wiring Diagram

CABLE SELECTION GUIDE FOR INTRINSIC SAFETY

TYPE <small>(SEE NOTE 2)</small>	MANUFACTURERS <u>BELDEN</u> <u>ALPHA</u> <u>COLOR CODE</u>			GROUP C		GROUP D	
				TOTAL LENGTH	CHANNEL MAXIMUM	TOTAL LENGTH	CHANNEL MAXIMUM
				FEET <small>(SEE NOTE 3)</small>	LENGTH FEET <small>(SEE NOTE 4)</small>	FEET <small>(SEE NOTE 3)</small>	LENGTH FEET <small>(SEE NOTE 4)</small>
MAG. PROBE MP450, MP460 (PAT.7100 series)							
S	8441	-	BLK / RED	5300	3000	12000	3000
S	8761	2401C	BLK / CLR	9200	4600	16000	4600
S	82761	-	BLK / RED	9200	4600	16000	4600
S, B	83552	-	BLK / WHT	6000	3000	12000	3000
3-WIRE OPTO-SENSOR ES825 series, ES820-100 (ELS-1100)							
NS	8443	1173C	BLK / RED / GRN (BELDEN) BLK / RED / WHT (ALPHA)	2700	2700	11300	5500
S	9608	6327	BLK / RED / WHT	2600	2600	11000	5500
S	-	2403C	BLK / RED / WHT	3800	3800	16000	5500
S, B	83553	-	BLK / RED / WHT	2700	2700	11000	5500
4-WIRE OPTO SENSOR ES820-200 (ECS-1100)							
NS	8444	1174C	BLK / RED / WHT / GRN	2700	2700	11300	5500
S	9609	6328	BLK / RED / WHT / GRN	2600	2600	11000	5500
S	-	2404C	BLK / RED / WHT / GRN	4000	4000	16000	6500
S, B	83554	-	BLK / RED / WHT / GRN	2800	2800	11000	5500

NOTES:

1.) ALL CABLES SPECIFIED HAVE A NOMINAL PAIR INDUCTANCE OF 0.2uH / FT.

2.) TYPE SPECIFIERS

NS = NON-SHIELDED

S = SHIELDED

B = DIRECT BURIAL (IF ALLOWABLE PER LOCAL CODES)

3.) TOTAL LENGTH:

MAG. PROBES – TOTAL COMBINED CABLE LENGTH FOR ALL MAG. PROBES

LEAK SENSORS – TOTAL COMBINED CABLE LENGTH FOR ALL LEAK SENSORS

4.) CHANNEL MAXIMUM LENGTH: MAXIMUM CABLE LENGTH PER MAG. PROBE OR SENSOR.

5.) FOR OPTO-SENSORS, SHIELDED CABLE IS NOT REQUIRED, BUT IF USED IN THE APPLICATION, THE SHIELD MUST BE CONNECTED TO “SHD” TERMINAL IN CONSOLE I.S. COMPARTMENT.

Figure 12C-Wiring Chart.eps 07-05-05

5. Pull properly marked 2 to 4 conductor wiring (depending on probe/sensor configuration) for each probe/sensor through the conduit leaving at least 24 inches excess at both console and junction box ends for final connections. The field wires must be resistant to hydrocarbon liquids; type THHN or MTW, 22 AWG is recommended. Use Belden Cable part number 8441, or equivalent 2-conductor shielded cable, for the magnetostrictive probes only. This cable can be supplied by PNEUMERCATOR as part number CW1-0500.
6. Fill all conduit VAPOR SEAL-OFF FITTINGS with approved filling compound and tighten all conduit fittings.
7. Splice all probe/sensor wires to the respective conduit wires at each WATERTIGHT JUNCTION BOX. (See Figure 3-4 for a recommended procedure). Maintain correct color-coding and polarity between wires.
8. Connect probe/sensor wires to the TMS2000 INPUT TERMINALS following Figure 3-1. Maintain correct polarity between wires and respective terminal points.
9. Probes and sensors should be logically identified as to location and type and recorded on the probe map provided in this manual, SECTION 3.6.

CAUTION

Probe and sensor wires are to be connected ONLY to the designated input terminals of the INTRINSIC SAFETY compartment. Do NOT allow probe/sensor wires to cross over into the non-intrinsically safe section. FAILURE TO COMPLY MAY RESULT IN PERSONAL INJURY, PROPERTY LOSS AND EQUIPMENT DAMAGE.

3.2 POWER WIRING INSTALLATION

IMPORTANT! LC2000 AND TMS SERIES GROUND WIRING INSTRUCTIONS

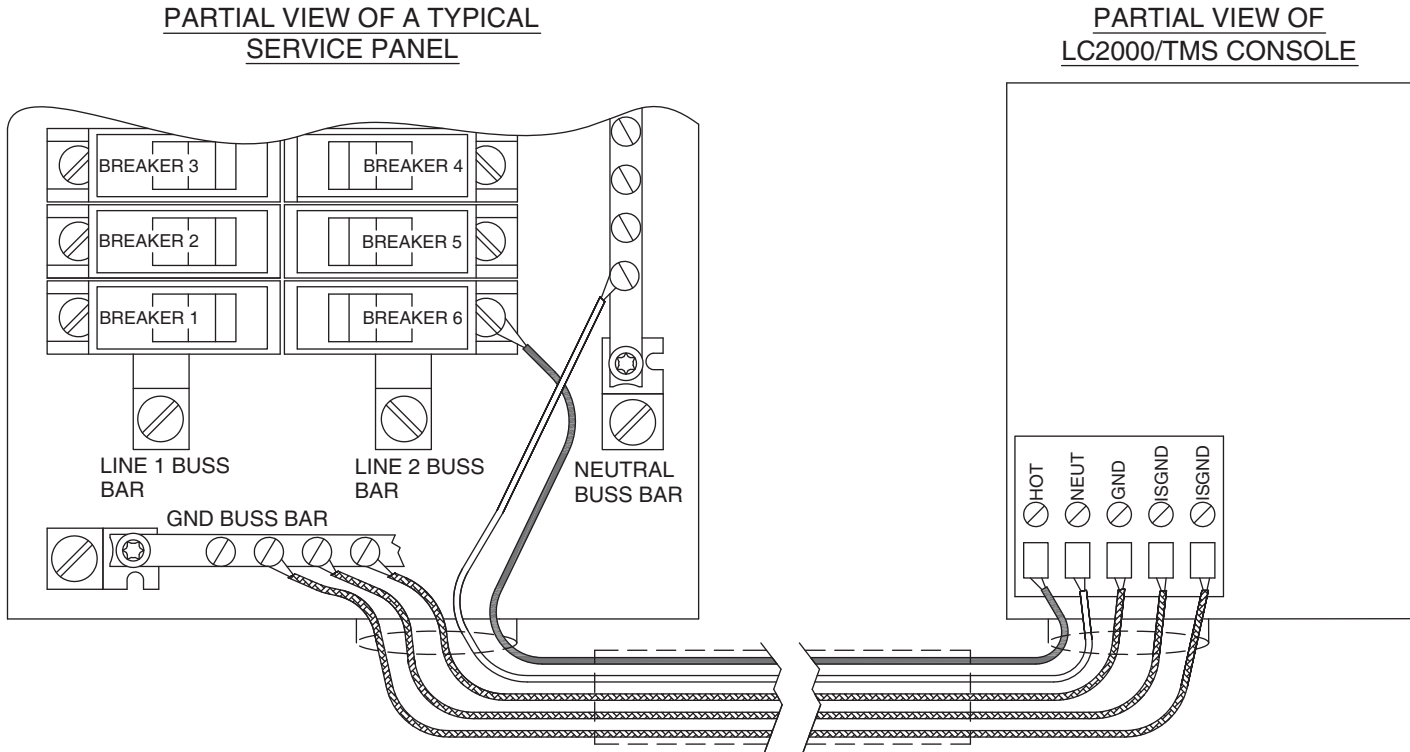

NOTE:
 ALL GROUNDS MUST BE TERMINATED AT THE GND BUSS BAR IN THE SAME SERVICE PANEL AS LC2000 AND/OR TMS POWER. A GROUNDING ROD, COLDWATER PIPE OR OTHER CONNECTION SHOULD NOT BE USED.

Figure 3-3 - TMS AC Power Wiring



IMPORTANT! PROBE WIRING INSTRUCTIONS - MODELS TMS2000 AND TMS3000

WARNING
 Refer to TMS installation manual for WARNINGS and CAUTIONS before proceeding. FAILURE TO COMPLY MAY RESULT IN PERSONAL INJURY, PROPERTY LOSS AND EQUIPMENT DAMAGE.

PROBE MODELS COVERED BY THIS BULLETIN	
MP450S	MP461SC
MP451S	MP461S[A], [V]
MP452S	MP462S[A], [V]
	MP463S[A], [V]

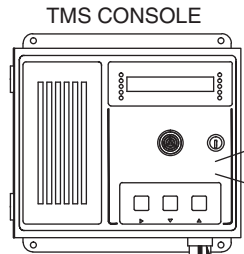

TYPICAL WIRING FOR TMS CONSOLES

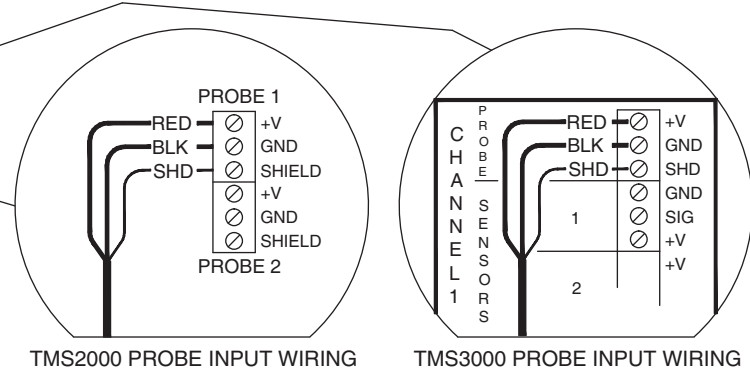

3/4" NPT (TMS2000)
 1" NPT (TMS3000)
 OR EQUIVALENT
 CONDUIT FITTING

NON-INTRINSICALLY SAFE WIRING
 INTRINSICALLY SAFE WIRING

NON-HAZARDOUS AREA

HAZARDOUS AREA
 CLASS 1, GROUPS C,D

CONDUIT AND VAPOR SEAL FITTING
 (SIZE AND LOCATION TO BE
 DETERMINED BY QUALIFIED INSTALLER)

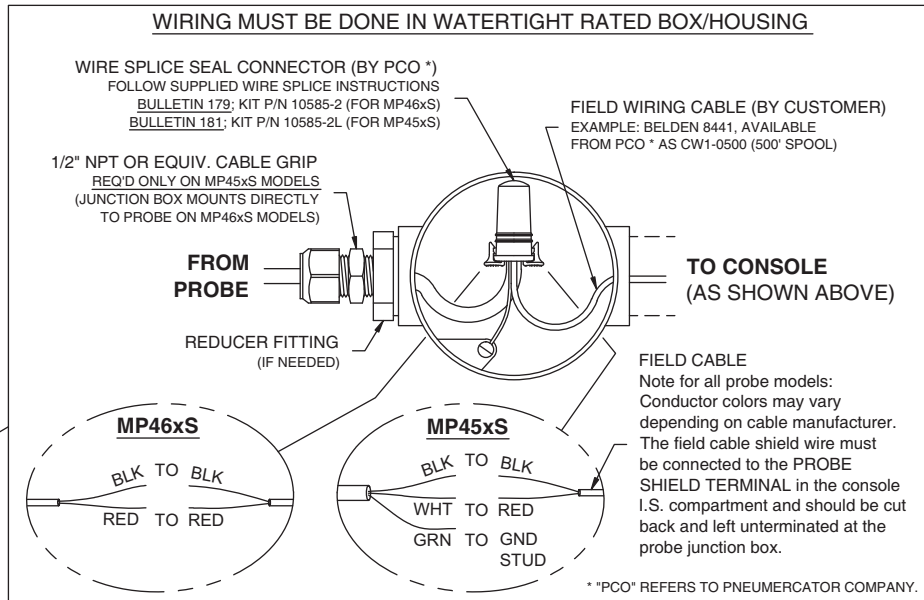
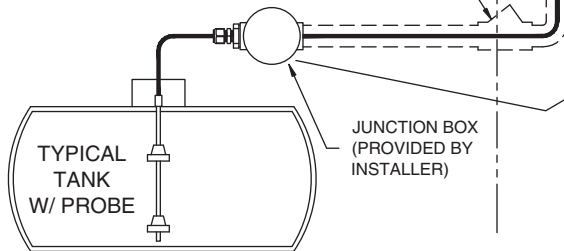

Figure 3-4 - MP45xS Cable Splice and Wiring

Bulletin 199 Rev. A (04/12/10)



Page 1 of 1

WIRE SPLICE AND SEAL INSTRUCTIONS - 2 CONDUCTOR PAIRS KIT 10585-2L

WARNING: USE CONNECTORS ONLY FOR THEIR DESIGNATED PURPOSE. DO NOT USE FOR AC WIRING.

1

BREAK APART

OUTER SLEEVE

(2) "V" SLOTS

INNER SLEEVE

USE TO SEAL MP45x PROBE CABLE SPLICES

SPLICE SEAL WIRE CONNECTOR PROVIDED BY PNEUMERCATOR

2

STRIP WIRES

FIELD CABLE *

1.25"

.75"

* PROBE FIELD CABLE SHIELD WIRE HAS NO CONNECTION

MP45x PROBE CABLE

1.25"

.75"

STRIP GREEN WIRE AS NEEDED TO CONNECT TO JUNCTION BOX GROUND STUD

3

GREEN GROUND WIRE

TWIST WIRES (EXCEPT FOR GND WIRE)

4

BEND OVER GROUND WIRE AS SHOWN

INSERT

5

PULL ONE TWISTED LEAD PAIR THROUGH EACH "V" AND BEND OVER

6

SNAP ON OUTER SLEEVE

DO NOT ROTATE OR TWIST OUTER SLEEVE

DO NOT REUSE

CONNECT GND WIRE TO JUNCTION BOX GND STUD

Figure 3-5 - MP45xS Splice Kit Instructions

WIRE SPLICE AND SEAL INSTRUCTIONS - 2 CONDUCTOR PAIRS KIT 10585-2

WARNING: USE CONNECTORS ONLY FOR THEIR DESIGNATED PURPOSE. DO NOT USE FOR AC WIRING.

1

BREAK APART

(2) "V" SLOTS

OUTER SLEEVE

INNER SLEEVE

USE TO SEAL 2-WIRE SENSOR AND/OR MP46x PROBE CABLE SPLICES

SPLICE SEAL WIRE CONNECTOR PROVIDED BY PNEUMERCATOR

2 STRIP WIRES

FIELD CABLE *

1.25"

.75"

* PROBE FIELD CABLE SHIELD WIRE HAS NO CONNECTION

2-WIRE SENSOR OR MP46x PROBE CABLE

1.25"

.75"

3

TWIST WIRES

4

INSERT

5

PULL ONE TWISTED LEAD PAIR THROUGH EACH "V" AND BEND OVER

6

SNAP ON OUTER SLEEVE

DO NOT ROTATE OR TWIST OUTER SLEEVE

DO NOT REUSE

Figure 3-6 - MP46xS and 2-wire sensor Splice Kit Instructions

WIRE SPLICE AND SEAL INSTRUCTIONS - 3 CONDUCTOR PAIRS KIT 10585-3

WARNING: USE CONNECTORS ONLY FOR THEIR DESIGNATED PURPOSE. DO NOT USE FOR AC WIRING.

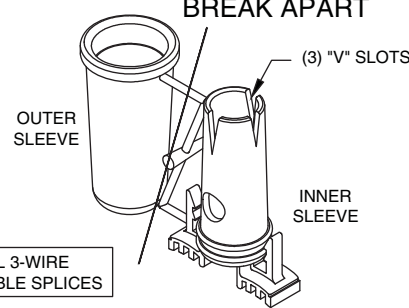
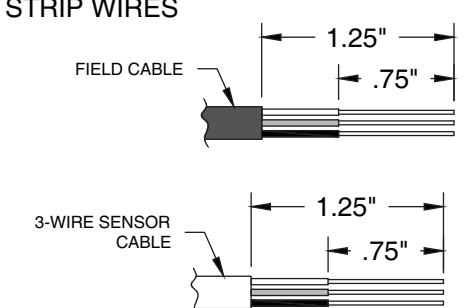
<p>1</p>  <p>USE TO SEAL 3-WIRE SENSOR CABLE SPLICES</p> <p>SPLICE SEAL WIRE CONNECTOR PROVIDED BY PNEUMERCATOR</p>	<p>2 STRIP WIRES</p> 
---	--

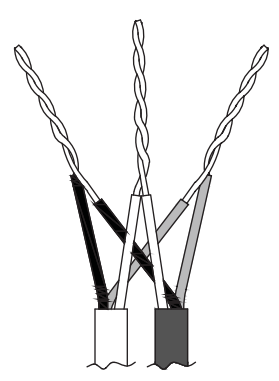
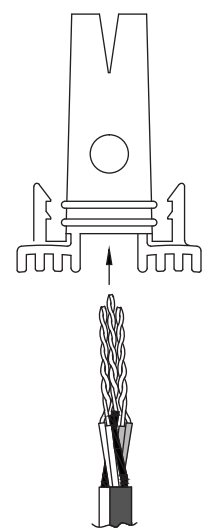
<p>3</p>  <p>TWIST WIRES</p>	<p>4</p>  <p>INSERT</p>
---	--

<p>5</p>  <p>PULL ONE TWISTED LEAD PAIR THROUGH EACH "V" AND BEND OVER</p>	<p>6</p> <p>SNAP ON OUTER SLEEVE</p> <p>DO NOT ROTATE OR TWIST OUTER SLEEVE</p> <p>DO NOT REUSE</p> 
--	--

Figure 3-7 - 3-wire sensor Splice Kit Instructions

IMPORTANT! TMS2000 SENSOR WIRING INSTRUCTIONS

IDENTIFY THE TYPE OF SENSOR(S) TO BE INSTALLED. WIRING MUST BE TERMINATED ON THE TERMINALS INDICATED BELOW TO ENSURE CORRECT OPERATION.

2-WIRE SENSORS

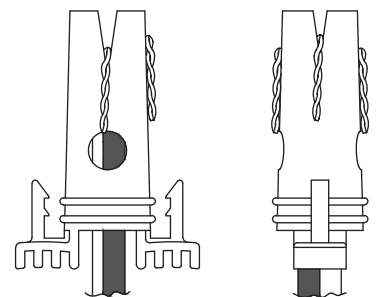
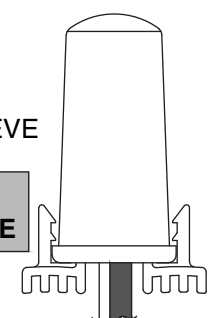
NOTE: "S" = SIGNAL AND IS CONSECUTIVELY NUMBERED "S1" THROUGH "S8" ON THE TMS2000 CIRCUIT BOARD

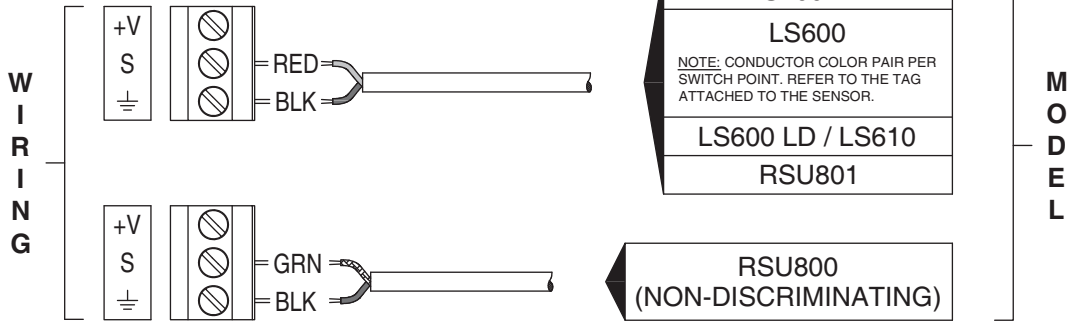

3-WIRE SENSORS

NOTE: "S" = SIGNAL AND IS CONSECUTIVELY NUMBERED "S1" THROUGH "S8" ON THE TMS2000 CIRCUIT BOARD

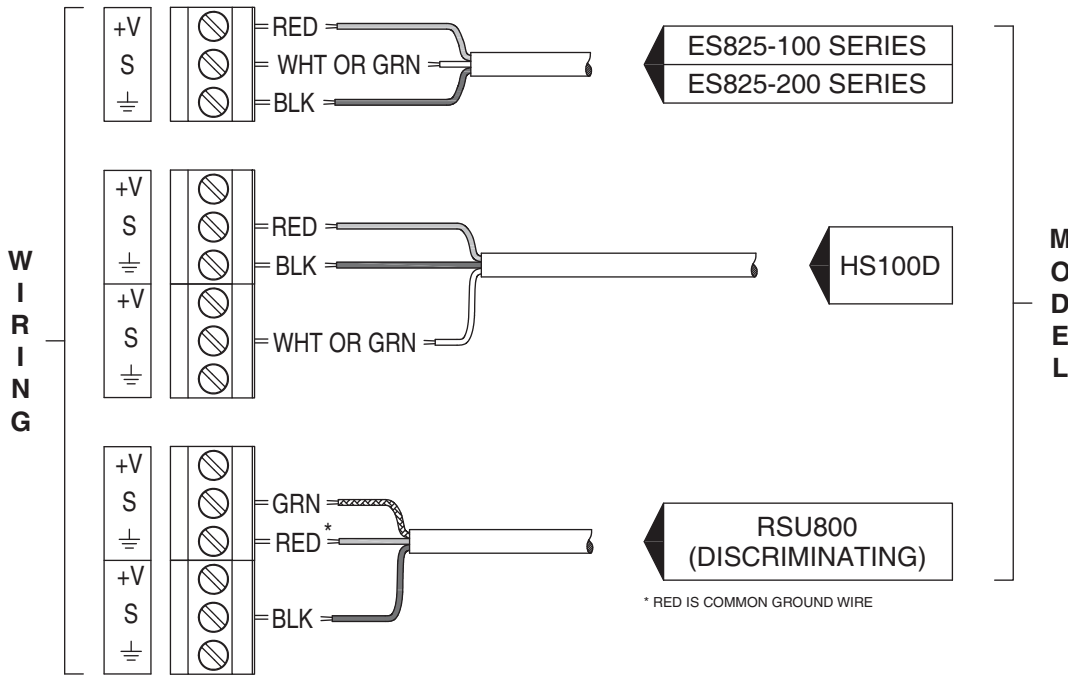

Questions? Contact Technical Support at (800) 209-7858



Figure 3-8 - TMS2000 sensor wiring

3.4 PROGRAMMABLE RELAY OUTPUTS/CONTACT CLOSURE INPUTS

The TMS2000 provides dry contact closure inputs and relay contact closure outputs that are user-programmable via the console front panel or most TMS communications interfaces. Each input is programmable for relay control and alarm functions as well as remote relay acknowledgement or gating functions. Inputs may also be programmed to monitor submersible pump or generator activity in conjunction with the TMS Series AUTO LEAK TEST mode. Each relay output is programmable to trigger on any combination of events, including in-tank leak, theft, product or water setpoints, leak or point level sensor alarm, contact closure input or system error. Additionally, relays are individually programmable for failsafe mode; delayed shutoff mode and a latching mode for pump up/down functions. Typical relay applications include remote annunciation, pump and siphon break/flow control valve operation, and other user-defined switch closure inputs. These relays also provide a simple and straightforward interface to most programmable logic controllers, building management systems, and similar input monitoring devices.

The standard TMS2000 includes two (2) dry contact closure inputs and two (2) relay contact closure outputs as illustrated in Figure 3-9 below. Also shown is an optional 4 Input/4 Relay Output Card. An optional 8 Input/8 Relay Output Card or 16 Relay Output Card is available.

⚠ CAUTION

Relay output and contact closure input terminals are located on the NON-INTRINSICALLY SAFE side of the console. ALL wiring to these terminals MUST enter through the designated conduit opening. Refer to FIGURE 1-3. FAILURE TO COMPLY MAY RESULT IN PERSONAL INJURY, PROPERTY LOSS AND EQUIPMENT DAMAGE.

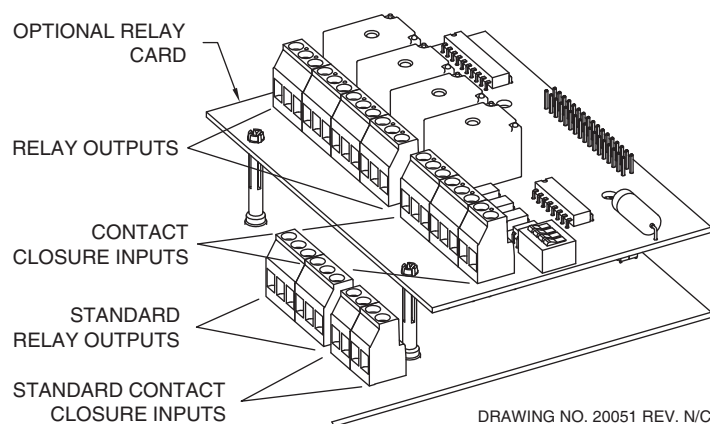

Figure 3-9 - Relay Output/Contact Closure Input Layout
(Optional 4 Relay Output/4 Contact Closure Input Expansion Card shown)

3.5 DATA COMMUNICATIONS WIRING

The console's power area is equipped with three (3) communications ports that are assigned as follows:

One (1) for external EIA RS-232 Interface to externally mounted computers or modems.

One (1) for external EIA RS-485 Interface to externally mounted PNEUMERCATOR smart peripheral control devices.

One (1) for use with an optional communications expansion board.

Figure 3-10 shows the locations of these ports.

⚠ CAUTION

All communication terminations are located in the NON-INTRINSICALLY SAFE side of the TMS2000 console. ALL wiring to these terminals MUST enter the designated conduit opening. Refer to FIGURE 1-3. FAILURE TO COMPLY MAY RESULT IN PERSONAL INJURY, PROPERTY LOSS AND EQUIPMENT DAMAGE.

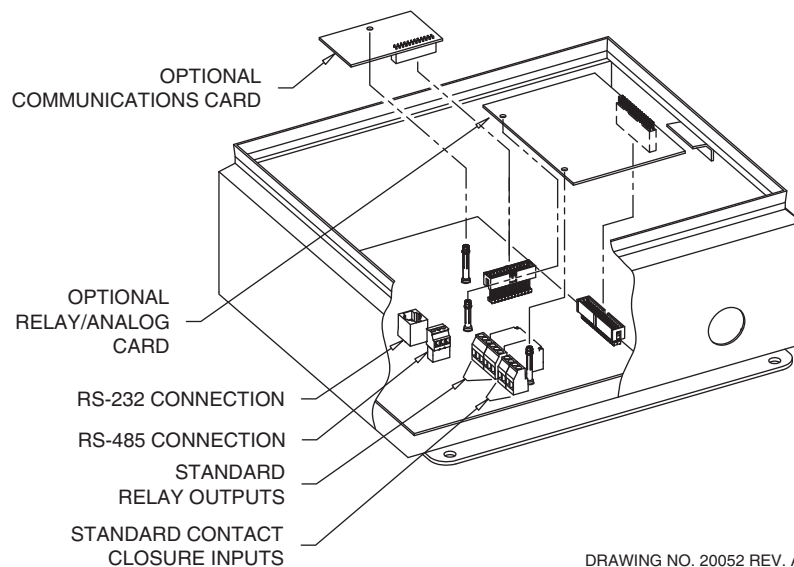

Figure 3-10 - Non-Hazardous Expansion Option Installation

3.6 PROBE MAP/SYSTEM SETUP

The probe map/system setup below should be completed by the electrical installer as each probe, sensor and control output function is wired to the TMS2000 system. This will provide the equipment operator a means of identifying each field device for proper system setup programming and use. The PROBE MAP should be adhered to or kept near the TMS2000 console.

PROBE MAP/SYSTEM SETUP

TANK	PRODUCT	SP 1	SP 2	SP 3
1				
2				

CHNL	LEAK INPUT USAGE	SENSOR
1		
2		
3		
4		
5		
6		
7		
8		

CHNL	AUX/SWITCH INPUT USAGE	SENSOR
1		
2		
3		
4		
5		
6		
7		
8		

RELAY	ALARMS	USAGE
1		
2		
3		
4		
5		
6		
7		
8		
9		
10		
11		
12		
13		
14		
15		
16		
17		
18		

PNEUMERCATOR TMS SERIES

LIMITED WARRANTY

TMS Series

Pneumercator, here and after referred to as **PCO**, warrants its **TMS Series** family of products to be free of defects in material and workmanship for a period of **Twelve (12) months** from date of installation or **Fifteen (15) months** from date of invoice, whichever comes first.

During the warranty period on the **TMS Series**, **PCO**, or factory third party independent representatives will repair or replace the product at the location where it is installed at no additional cost to the customer.

Packages must be inspected upon receipt for damage, missing parts, and/or manuals. **PCO** must be contacted by telephone immediately with a description of damaged or missing parts so replacements can be sent. Written details must be sent within **thirty (30) days**.

Pneumercator will not be responsible for shipping charges incurred by the customer.

Warranty repair coverage invoices will be paid if **all** the following conditions are met:

- PCO has acknowledged and authorized warranty work to be done by issuing a *Warranty Repair Number*.
- Start-up Service technician has been trained by PCO
- Warranty start-up form has been submitted to PCO
- Technician fills out and submits a PCO "Service Report"
- Parts (if any) used are returned to PCO with a proper WRGA (*Warranty Return Goods Authorization*)
- Returned parts are found to be defective.

Repair time will be paid according to PCO document "Standard Warranty Labor Charge Schedule"

If the Warranty Registration/Start up Check List has been completed and returned on file with the factory and the product is installed in accordance with the specific PCO Installation Product Manual, PCO will activate and meet warranty criteria as described above. Warranty criteria shall be voided if any product has been subjected to misuse, negligence, damage from acts of nature (lightning, wind, rain, etc.) or is in violation of the products design intent, disregard to warnings, instructions, modified or repaired by unauthorized personnel or improperly installed. Given that the third party independent contractor has installed the equipment in accordance with the specific product instruction manual, and followed all precautions, PCO will fulfill the terms stated in our warranty obligation.

Under no circumstances does the warranty provide a remedy in excess of the equipment. No other expressed or implied warranty is given by PCO. PCO shall not be liable for consequential damages or any expenses incurred by the user.

Distributed by:

 **PNEUMERCATOR**
Liquid Level Control Systems

1785 Expressway Drive North, Hauppauge NY 11788
(631) 293-8450 Fax (631) 293-8533

--