

# INSTRUCTION MANUAL

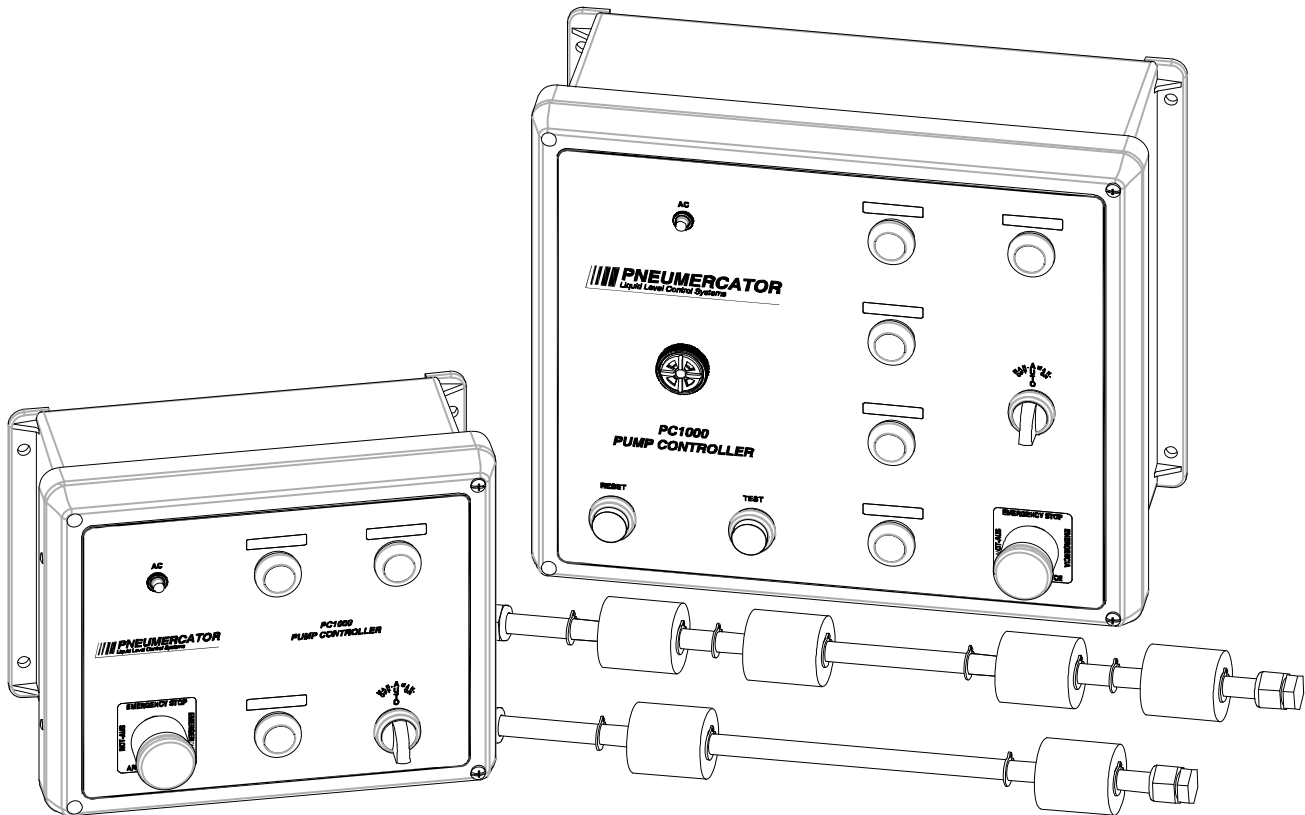

DRAWING NO. 20147 REV. A

## **PC1000-A SERIES**

**© COPYRIGHT 2018 PNEUMERCATOR CO., INC.  
1785 EXPRESSWAY DRIVE NORTH  
HAUPPAUGE, NY 11788**

(631) 293-8450 Phone  
(631) 293-8533 Fax  
(800) 209-7858 Support  
[www.pneumercator.com](http://www.pneumercator.com)



TABLE OF CONTENTS

	Page
SAFETY INFORMATION .....	5
Section 1 PRODUCT DESCRIPTION	
1.1 General System Overview .....	6
1.2 Control Console Description .....	7
1.3 Liquid Sensor Description .....	10
Section 2 INSTALLATION DETAILS	
2.1 Installation Checklist .....	11
2.2 Control Console Installation.....	12
2.3 Sensor Installation.....	13
Section 3 WIRING INSTALLATION AND DIAGRAMS	
3.1 PC Board Setup and Layout.....	14
3.2 System Wiring .....	16
3.3 Sensor Map/System Setup.....	20
3.4 Installation as a Remote Alarm Panel.....	20
Section 4 OPERATION	
4.1 General.....	21
4.2 Horn Control.....	21
Section 5 TROUBLESHOOTING	
5.1 General.....	22
5.2 Spare Parts List.....	22
Section 6 MAINTENANCE/TESTING	
6.1 Console.....	23
6.2 Sensors.....	23



**⚠ IMPORTANT SAFETY INFORMATION**

**This manual contains instructions for installing electrical hardware in explosion hazard areas.**

**The following warnings must be considered to be in compliance with accepted codes.**

**Any inquiries about this manual, or to return defective equipment should be directed to:**

**PNEUMERCATOR COMPANY  
1785 EXPRESSWAY DRIVE NORTH  
HAUPPAUGE, NY 11788  
Attention: Technical Services  
TEL: (631) 293-8450  
FAX: (631) 293-8533  
TOLL FREE: (800) 209-7858  
[www.pneumercator.com](http://www.pneumercator.com)**

**⚠ WARNING**

**Installation must be in strict accordance with this manual as adopted from the following codes:**

**- ISA RP12.6, "Installation of intrinsically Safe Instrument Systems in Class I Hazardous Locations."**

**- NFPA 70, "National Electric Code."**

**- NFPA 30A, "Automotive and Marine Service Station Code."**

**FAILURE TO COMPLY MAY RESULT IN PERSONAL INJURY, PROPERTY LOSS AND EQUIPMENT DAMAGE.**

**⚠ WARNING**

**Alteration, modification or replacement with non-factory components could impair the intrinsic safety of this equipment, and void the warranty. FAILURE TO COMPLY MAY RESULT IN PERSONAL INJURY, PROPERTY LOSS AND EQUIPMENT DAMAGE.**

**SECTION 1 – PRODUCT DESCRIPTION**

**1.1 GENERAL SYSTEM OVERVIEW**

The basic function of the Model PC1000-A Pump Control console is to provide automated pump and/or solenoid valve control at the occurrence of high, or low levels: typically via float switches, or any tank mounted sensing device that transmits a condition by opening or closing dry switch contacts. The console also includes a momentary manual override switch to provide the user with the means of bypassing the automated controls. An Emergency Stop switch is also provided to immediately stop the pump should a critical situation arise. The PC1000-A may also be used as a non-intrinsically safe remote pump control panel for any system that provides a dry contact relay output to represent a specific set of conditions. The console is powered by 120 VAC and includes an integrated Pump On light and AC Power light. The PC1000-A also provides 2 to 4 input channels each with a corresponding light. Each input consists of a pair of intrinsically safe terminals for wiring to field mounted switches. The intrinsically safe inputs allow mounting the switches in explosion hazard environments without requiring additional protective barrier components in the wiring runs. Start and Stop pump control inputs manipulate the integrated Pump Control Output Relay. For every alarm input, there is a single dry contact relay output that can be used to signal a remote alarm device or control an external electrical device, such as a solenoid valve, up to 10A @ 120 VAC.

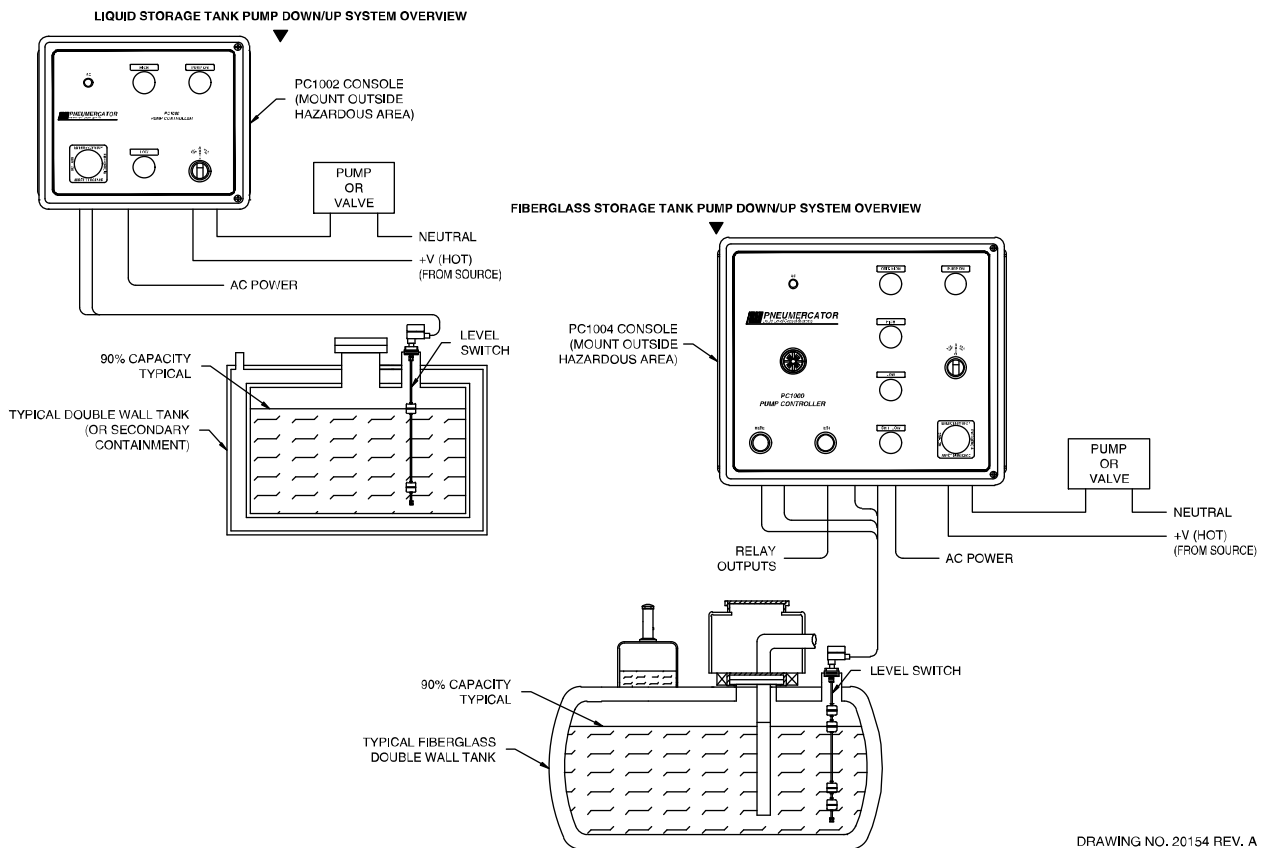

DRAWING NO. 20154 REV. A

**Figure 1-1 - PC1000-A Series Overview**

## 1.2 CONTROL CONSOLE DESCRIPTION

The console is housed in a NEMA 4X (weather tight/corrosion resistant) FRP (fiberglass reinforced plastic) enclosure for mounting in the non-hazardous area. Each unit operates on 120 VAC power and provides from two (2) to four (4) intrinsically safe alarm channels for monitoring up to four independent sensing points. A green AC power LED, bright yellow High and Low pump control LEDs, a green Pump On LED, red alarm LEDs, one for each alarm channel, and a horn are mounted to the enclosure cover.

Each alarm channel is equipped with a 1 Form C output relay, totally isolated from the sensor inputs, rated for 10A@120VAC, for controlling external devices such as remote alarm annunciators. All field wiring is made through pressure-type terminal blocks enclosed under metal barriers to separate the power from the intrinsically safe wiring. Figures 1-2 and 1-3 illustrate the standard PC1000-A outline, mounting flange locations, and dimensions.

The console should be located in an area that is easily accessible to the personnel responsible for operation and maintenance of the system. Use only dedicated conduit entries for their designated purpose as specified in Figure 1-4. Metal conduiting is recommended and may be required by local codes. All outdoor conduits must be watertight.

### **⚠ WARNING**

**Installation MUST be done by qualified personnel familiar with local wiring codes and explosion hazard electrical safety practices. FAILURE TO COMPLY MAY RESULT IN PERSONAL INJURY, PROPERTY LOSS AND EQUIPMENT DAMAGE.**

### **⚠ WARNING**

**The console is designed for Ordinary Location, Non-Hazardous installation only, as defined by the National Electrical Code (NEC). DO NOT install where flammable vapors may be present. FAILURE TO COMPLY MAY RESULT IN PERSONAL INJURY, PROPERTY LOSS AND EQUIPMENT DAMAGE.**

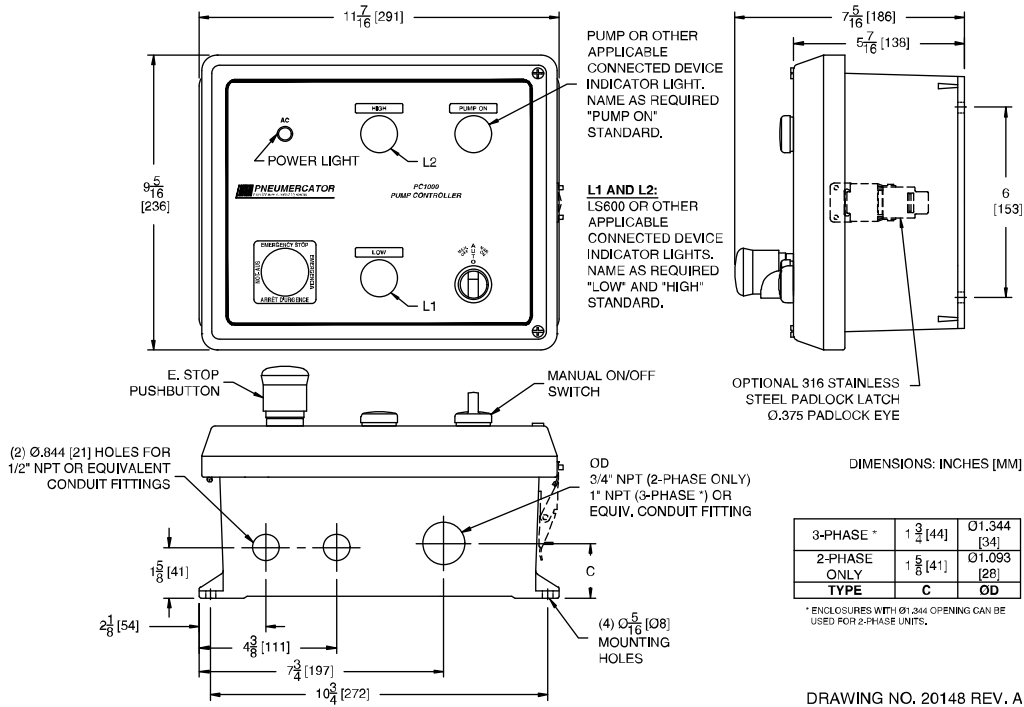

Figure 1-2 - PC1002 Console Outline

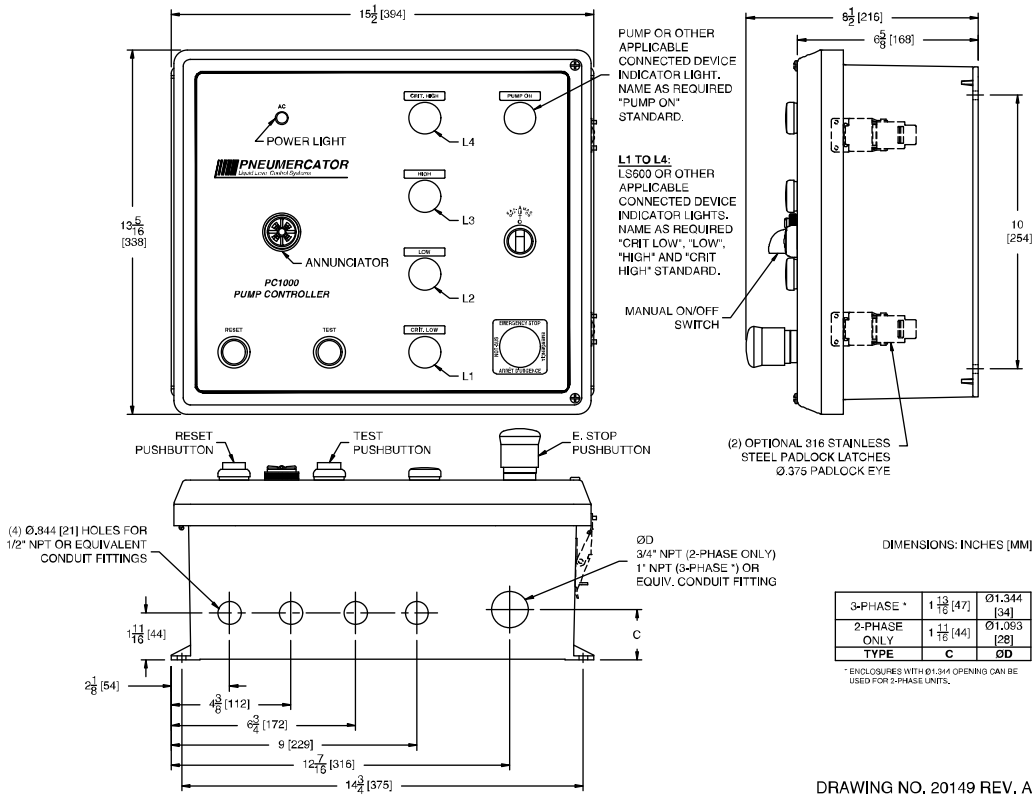

Figure 1-3 - PC1003/4 Console Outline



**⚠ WARNING**

**Do not drill or modify enclosure. Use only conduit entries provided. FAILURE TO COMPLY WILL VOID WARRANTY AND MAY PRESENT A SAFETY HAZARD RESULTING IN PERSONAL INJURY, PROPERTY LOSS AND EQUIPMENT DAMAGE.**

**⚠ WARNING**

**Conduit entries must only be used for their designated purpose in order to assure safe operation and to maintain safety certification. FAILURE TO COMPLY WILL VOID WARRANTY AND MAY PRESENT A SAFETY HAZARD RESULTING IN PERSONAL INJURY, PROPERTY LOSS AND EQUIPMENT DAMAGE.**

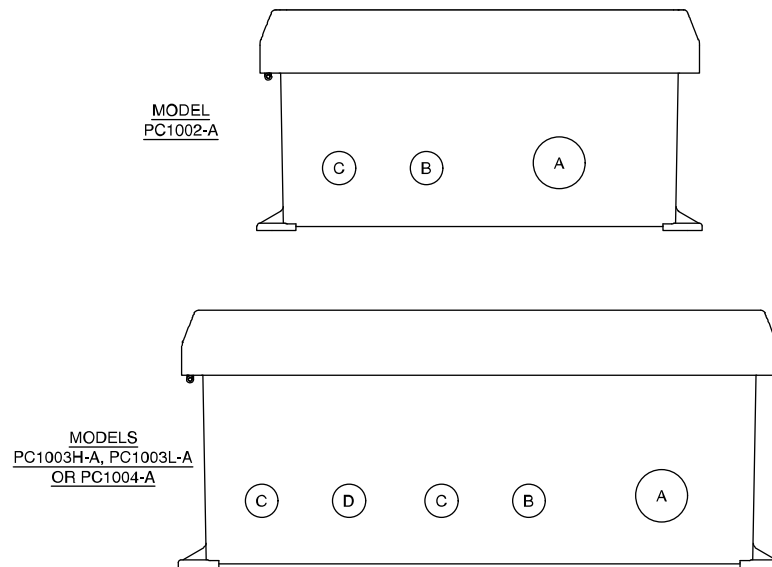

**NON-INTRINSICALLY SAFE  
CONDUIT OPENINGS AND  
DESIGNATED USES:**

1/2" NPT CONDUIT SIZE \*

ALL MODELS:  
B = POWER & EARTH GROUNDS  
PC1003H-A, PC1003L-A OR PC1004-A:  
D = RELAY OUTPUT(S)

1" NPT CONDUIT SIZE \*

ALL MODELS:  
A = PUMP CONTROL OUTPUTS

**INTRINSICALLY SAFE  
CONDUIT OPENINGS AND  
DESIGNATED USES:**

1/2" NPT CONDUIT SIZE \*

ALL MODELS:  
C = I.S. INPUTS

\* OR EQUIVALENT

DRAWING NO. 20226 REV. N/C

**Figure 1-4 - PC1000-A Conduit Usage**

1.3 LIQUID SENSOR DESCRIPTION

The PC1000-A is typically integrated with the LS600 family of sensors used for monitoring in-tank levels. The maximum number of supported floats is 4, depending on the overall job configuration; check the specific job design drawings for the actual number and type specified. Figure 1-5 shows the LS600 sensor provided by Pneumercator with their most typical applications. Other non-Pneumercator models may be used; however, their use with the PC1000-A should have been approved by Pneumercator and local regulators before attempting to wire them into the system.

MODEL SERIES		FEATURE <sup>2</sup>	FIGURE OR OUTLINE DRAWING	MODEL SERIES		FEATURE <sup>2</sup>	FIGURE OR OUTLINE DRAWING
		TEST LEVER				TEST LEVER	
LS600 <sup>1</sup>	S.S. OR BRASS STEM	NO	FIG. 1 (BELOW)	LS600M	S.S. STEM	NO	10620
		YES	FIG. 2 (BELOW)	LS600W	S.S. OR BRASS STEM	NO	FIG. 1 (BELOW)
	PVC STEM	NO	10660	LS600X	S.S. STEM	YES	10651
LS600F4	S.S. STEM	YES	10682		PVC STEM	NO	10678

<sup>1</sup> Single float catalog lengths for 2" NPT STANDARD TANK MOUNT shown in price book. Sized using INCHES as the unit of measure. Multiply by 25.4 for MILLIMETERS (mm) equivalent for "S" (set point), "SL" (sensing length) and "L" (stem length) dimensions.

<sup>2</sup> See outline drawing 10702 for ADJUSTABLE stem (requires bushing/flange) or 10704 for RISER SPACER MOUNT. Consult factory for other features.

<sup>3</sup> Optional 150-pound mounting flange or quick release cap (not shown) is available upon request. Consult factory for flange/cap size availability.

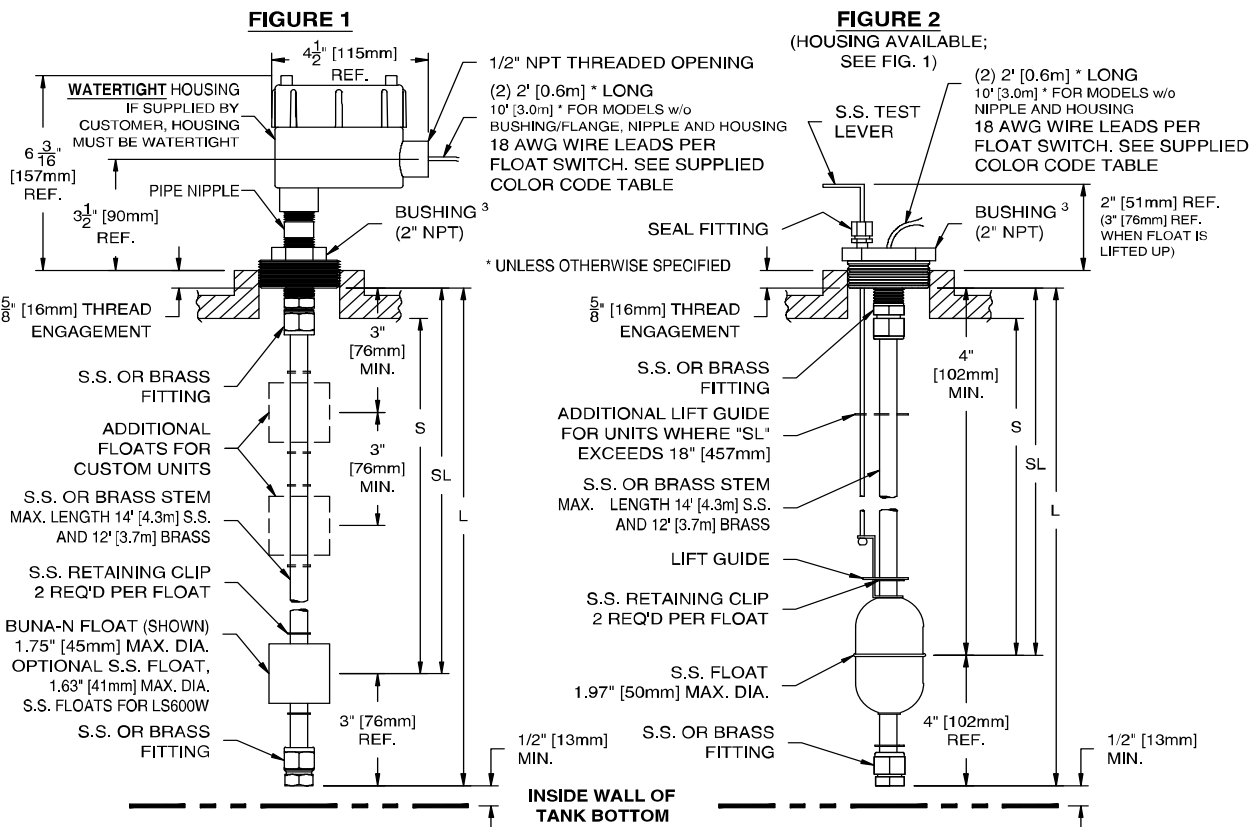

DRAWING NO. 20057 REV. B

Figure 1-5 – LS600 Series

(Refer to Bulletin 193 for Installation/Operation/Testing Instructions)

## SECTION 2 – INSTALLATION DETAILS

### 2.1 INSTALLATION CHECKLIST

#### **⚠ WARNING**

**Do NOT apply power to the PC1000-A until its installation has been checked and found to be in accordance with these instructions; National Electric Code; Federal, State and Local codes; and other applicable safety codes. FAILURE TO COMPLY MAY RESULT IN PERSONAL INJURY, PROPERTY LOSS AND EQUIPMENT DAMAGE.**

The following points should be reviewed in preparation for installation, and again when installation is complete.

1. Review the applicable wiring diagram from Figures 3-2 through 3-5 to ensure that all of the safety/wiring requirements have been met.
2. Check that all equipment at job site matches the DESIGN DRAWING SPECIFICATIONS for the tank sizes and control features required.
3. The console should be located as close as possible to the demarcation point of the hazardous area. **Never mount inside the hazardous area.**
4. POWER to the console should be properly wired to a DEDICATED 120 VAC CIRCUIT BREAKER. No other equipment can be powered from the same circuit breaker as the PC1000-A.
5. System cannot be connected to equipment that uses or generates more than 250 volts with respect to earth.
6. All PC1000-A grounds must be terminated at the GND BUSS BAR in the same service panel as PC1000-A power. A grounding rod, coldwater pipe or other connection should not be used.
7. **Do not drill or modify enclosure.** Use only conduit entries provided. Failure to comply will void warranty and may present a safety hazard.
8. WATERPROOFING FIELD WIRE SPLICES using factory supplied splice kits is required for proper system operation.

**2.2 CONTROL CONSOLE INSTALLATION**

The console is the center of operations for any tank monitor system therefore its location should be selected for the operator's convenience, or as specified on the DESIGN DRAWINGS.

Select a flat wall surface and prepare it with four wall-mounting inserts to accept up to 1/4-inch size bolts. Allow sufficient room for door to open and for conduit runs to enter **ONLY THE CONSOLE BOTTOM**. See Figures 1-2 or 1-3 for the appropriate console dimensions.

Note that the console is divided into two electrical areas:  
**INTRINSICALLY SAFE (LEFT SIDE)** for Sensor signals and IS Earth Grounds  
**NON-INTRINSICALLY SAFE (RIGHT SIDE)** for Power and Control

Figures 2-1 and 2-2 show the console interior, again indicating the power and signal separation. **THIS SEPARATION MUST BE MAINTAINED** when conduits are connected. Refer to Section 3 for electrical conduit and wiring.

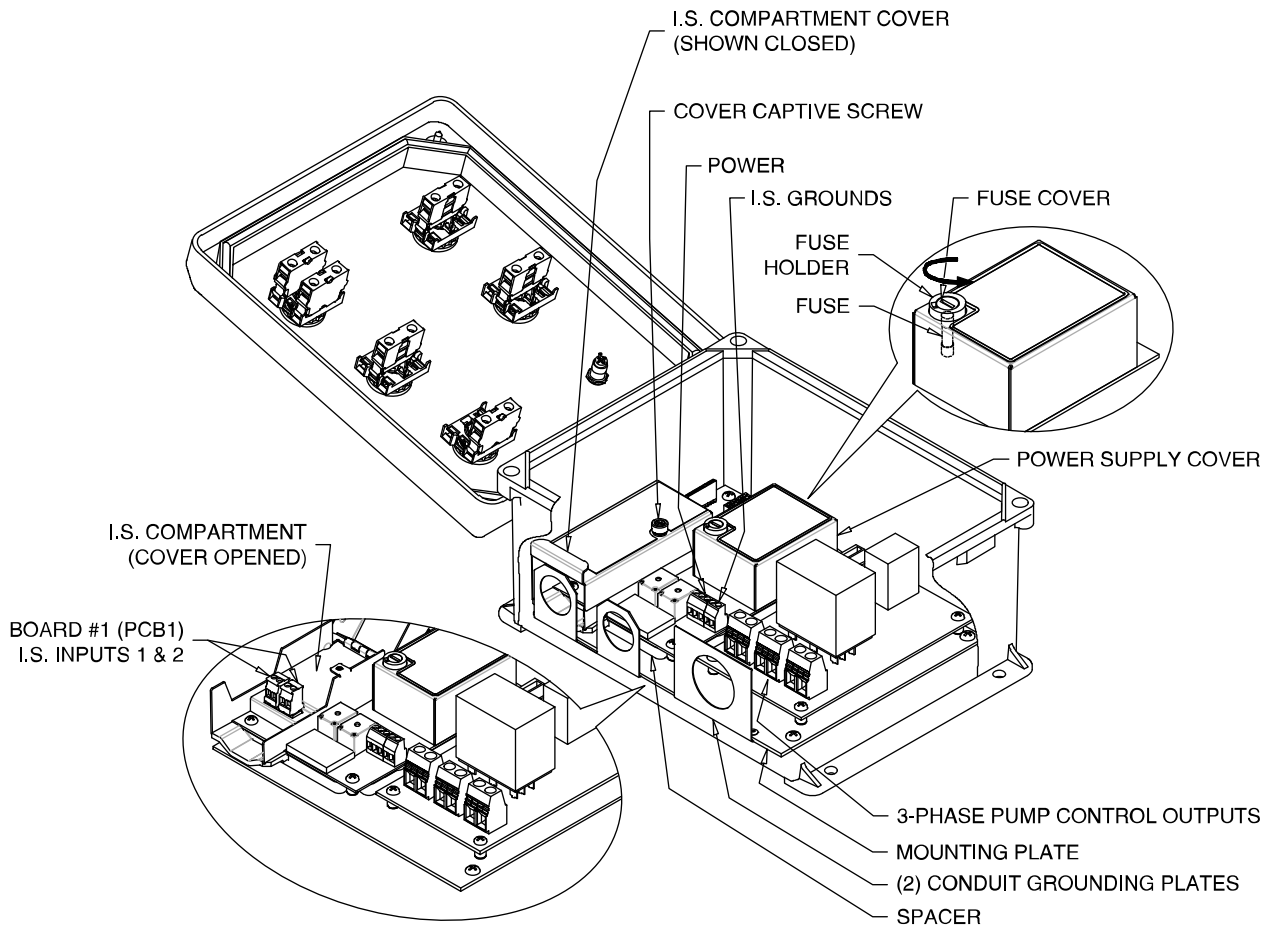

DRAWING NO. 20227 REV. N/C

**Figure 2-1 – PC1002-A Control Console Interior**

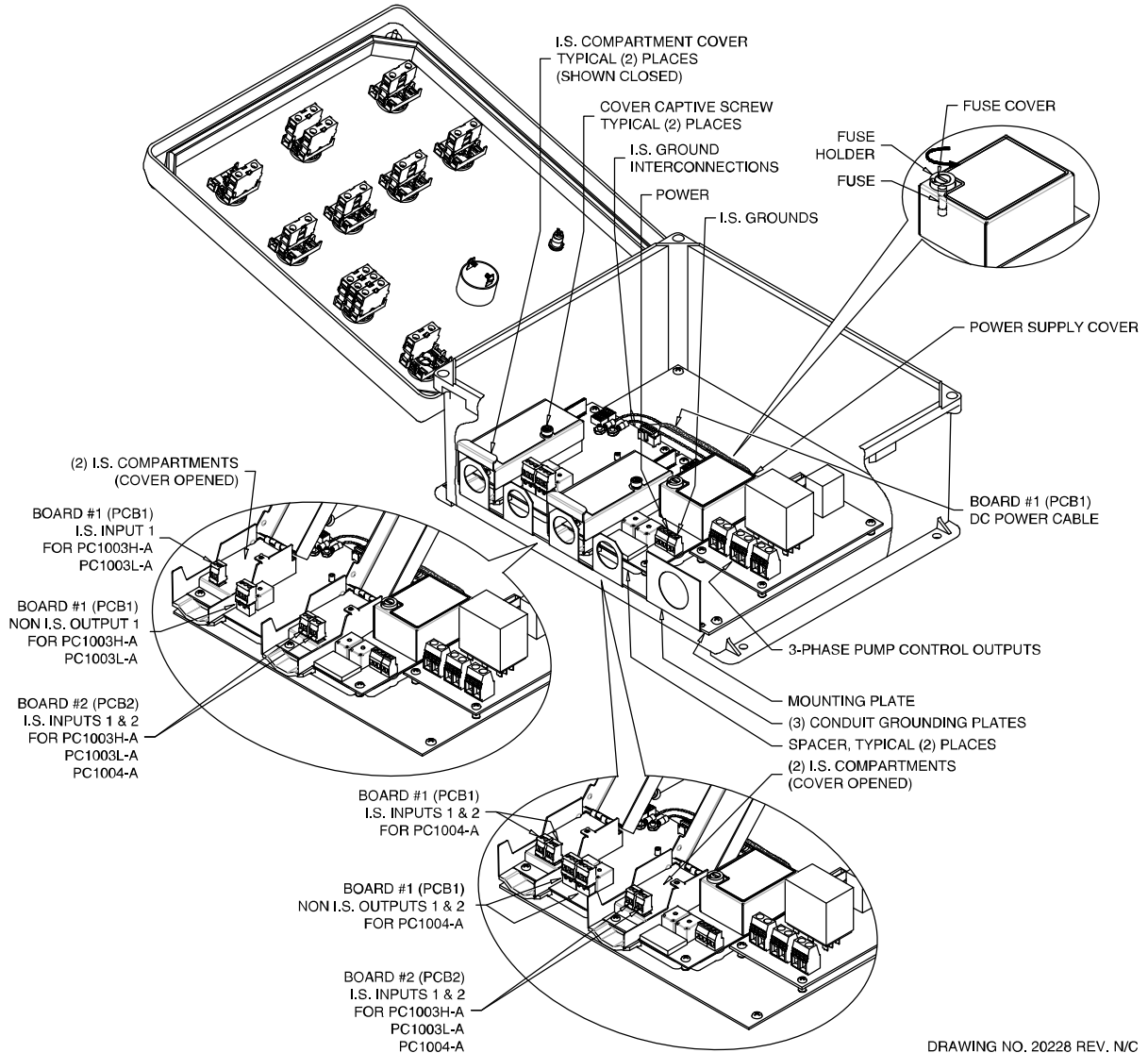

**Figure 2-2 – PC1003-A/1004-A Control Console Interior  
(PC1004-A shown)**

### 2.3 IN-TANK POINT SWITCHES

The PC1000-A has the electrical ability to read the continuity state of any dry contact sensor. As such, this system will support a variety of sensors from various manufacturers. However, your local regulations may not permit this combination as the PC1000-A has not been specifically approved for use with sensors not manufactured by Pneumercator. Please consult with your local regulators and with Pneumercator to discuss the compatibility of your particular sensor with the console and application.

The LS600 Sensor is covered in its own Instruction Bulletin 193 with the splice kit for the sensor covered by Bulletin 179.

These bulletins were supplied with each sensor and may also be downloaded from [www.pneumercator.com](http://www.pneumercator.com) by visiting the Tech Support section and scrolling down to Bulletins.

## **SECTION 3 WIRING INSTALLATION AND DIAGRAMS**

### **3.1 PC BOARD LAYOUT AND SETUP**

The PC1000-A Series includes either two (PC1002-A) or three (PC1003-A/PC1004-A) PC boards within the enclosure. The right-hand board is the Pump Control Output Relay Board. The remaining PC Boards will be setup at the factory for either Normally Open or Normally Closed operation. The switches will be configured at the factory to match the sensors provided on the order. Figure 3-1 on the following page includes a table detailing the switch settings for configuring inputs and relay outputs. **DO NOT CHANGE DIP SWITCHES ON THE PUMP CONTROL INPUT BOARD WITHOUT CONTACTING PNEUMERCATOR. THE PC1000-A WILL NOT OPERATE AS INTENDED WITH THE DIP SWITCHES IMPROPERLY SET.**

Each input may be configured to accept normally open or normally closed sensors. The PC1000-A is typically purchased with a Pneumercator LS600 Point Level Sensor.

All sensors will change the state of the corresponding relay upon activating. A DIP switch setting will identify the input as supporting an Alarm Sensor (activate the integrated horn) or a Relay Control Sensor (no effect on horn). Relay Control Sensors typically are used in conjunction with valve or indirect pump control applications.

Failsafe relay operation (normally energized) is enabled by DIP switch. The default switch setting has failsafe relay mode disabled (normally de-energized).

When acknowledging the internal PC1000-A horn by pressing the integrated Reset button, the state of the relay does not change from active to normal by default. The PC1000-A can be configured so that pressing the Reset button also returns the relay to its normal state. This is usually desired if a remote alarm system is connected to the PC1000-A relay. This feature is enabled by a DIP switch and is disabled by default.

The standard Autosilence feature on the PC1000-A may silence the integrated horn after a time delay of 1 to 9 minutes. The S1 rotary switch is used to configure the time delay. Setting S1 to zero disables this feature and is the default setting.

Note: Soldering on the boards is NOT permitted. ALL repairs to the boards must be performed at the factory.

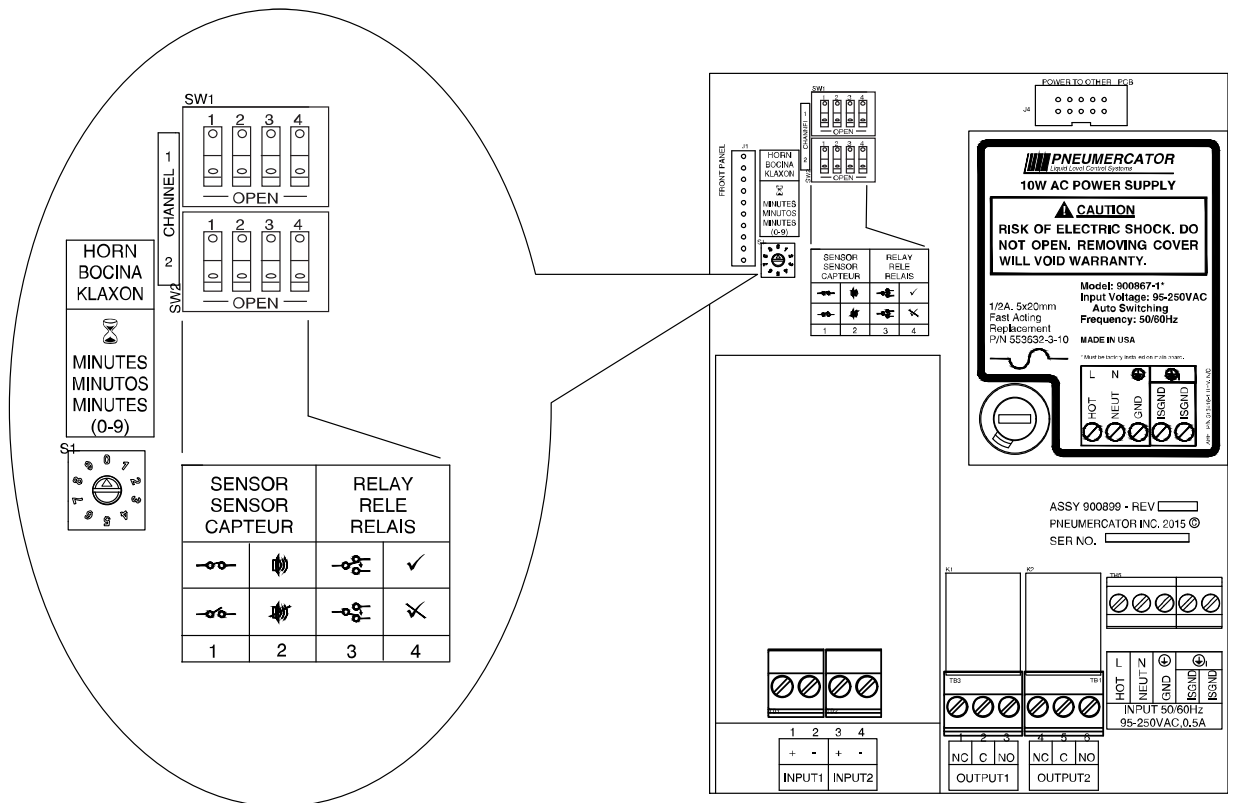

AUTOMATIC HORN SILENCE: 1-9 MINUTES. 0 = MANUAL ACKNOWLEDGMENT  
 SILENCIO AUTOMÁTICO DEL CUERNO: 1-9 MINUTOS. 0 = AGRADECIMIENTO MANUAL  
 AUTOMATIQUE SILENCIEUX: 1-9 MINUTES. 0 = RECONNAISSANCE MANUELLE

DIP SWITCH CONFIGURATION CONFIGURACIÓN DEL INTERRUPTOR DIP CONFIGURATION DU COMMUTATEUR DIP				
	SENSOR SENSOR CAPTEUR		RELAY RELÉ RELAIS	
	1 NORMAL CONTACT STATE ESTADO DE CONTACTO NORMAL ÉTAT DE CONTACT NORMAL	2 SENSOR MODE MODO SENSOR MODE CAPTEUR	3 NORMAL CONTACT STATE ESTADO DE CONTACTO NORMAL ÉTAT DE CONTACT NORMAL	4 FRONT PANEL ACKNOWLEDGE RECONOCIMIENTO DEL PANEL FRONTAL PANNEAU AVANT RECONNAISSANCE
CLOSED CERRADO FERMÉ	 CLOSED CERRADO FERMÉ	 ALARM (HORN & RELAY) ALARMA (BOCINA Y RELÉ) ALARME (KLAXON ET RELAIS)	 ON ENCENDIDO ACTIVÉ	✓ YES SÍ OUI
OPEN ABIERTO OUVERT	 OPEN ABIERTO OUVERT	 RELAY (RELAY ONLY) RELÉ (RELÉ SOLAMENTE) RELAIS (RELAIS SEULEMENT)	 OFF APAGADO ÉTEINT	✗ NO NO NON

Figure 3-1 – PC1000-A DIP Switch Configuration  
(Alarm Input/Output Board shown)

**⚠ CAUTION**

**While the console must NOT be located within the defined hazardous area, the sensors and associated wiring can be. For these applications, it is CRITICAL that electrical conduit and wiring be installed by qualified installers familiar with all provisions of the National Electrical Code relating to equipment intended for use in EXPLOSION HAZARD areas. The primary concern is to maintain physical separation between intrinsically safe and non-intrinsically safe wiring by running separate conduit attached to the control console at the designated knockouts. ALL conduits carrying sensor wiring into the hazardous area MUST be fitted with standard vapor seal-off fittings where the conduit first enters the non-hazardous area. FAILURE TO COMPLY MAY RESULT IN PERSONAL INJURY, PROPERTY LOSS AND EQUIPMENT DAMAGE.**



### 3.2 SYSTEM WIRING

Figures 3-2 through 3-5 are typical System Wiring Diagrams that must be followed when running conduit and wires between the HAZARDOUS TANK area and the NON-HAZARDOUS CONSOLE area. This follows electrical codes for proper installation.

SENSOR WIRING INSTALLATION. Refer to Figures 1-4 and 1-5 for console conduit openings and the LS600 sensor that will be wired into the PC1000-A system. Install wiring as follows:

1. Install 1/2" rigid conduit from all sensor areas to the PC1000-A console.

## **⚠ CAUTION**

**All sensor wiring from the PC1000-A console may be run in the same conduit. NO OTHER WIRING MAY BE RUN IN THESE CONDUITS. NEVER RUN POWER WIRES IN THESE CONDUITS. FAILURE TO COMPLY MAY RESULT IN PERSONAL INJURY, PROPERTY LOSS AND EQUIPMENT DAMAGE.**

2. At appropriate locations along the conduit runs (see LS600 Instruction Bulletin 193) install watertight couplings and approved VAPOR SEAL-OFF fittings.
3. At each sensor location install a WATERTIGHT ELECTRICAL JUNCTION BOX. Allow enough room around the sensor tank fitting for proper installation of the sensor and all conduit/junction box fittings, and for later removal if necessary.
4. Attach the conduit at the PC1000-A console ONLY to the 1/2" conduit knockout designated for Intrinsically Safe wiring (see Figure 1-4). Use NEMA 4 fittings for outdoor locations.
5. The alarm console is separated into two wiring sections, for each printed circuit board, by an aluminum cover. The wiring and terminal block on the left side are intrinsically safe and are physically separated from the AC power wiring on the right side. This separation must be maintained. Remove the protective cover by loosening the two hold-down screws. **IMPORTANT - SEPARATION BETWEEN INTRINSICALLY SAFE AND NON-INTRINSICALLY SAFE WIRING MUST BE MAINTAINED.**
6. Pull properly marked 2-conductor wiring for each sensor through the conduit leaving at least 24 inches excess at both console and junction box ends for final connections. The field wires must be resistant to hydrocarbon liquids; type THHN or MTW, 22 AWG is recommended.
7. Fill all conduit VAPOR SEAL-OFF FITTINGS with approved filling compound and tighten all conduit fittings.
8. Splice all sensor wires to the respective conduit wires at each WATERTIGHT JUNCTION BOX. (See Bulletin for a recommended procedure). Maintain correct color-coding for wires.

Figure 3-2 – PC1002-A Wiring Diagram

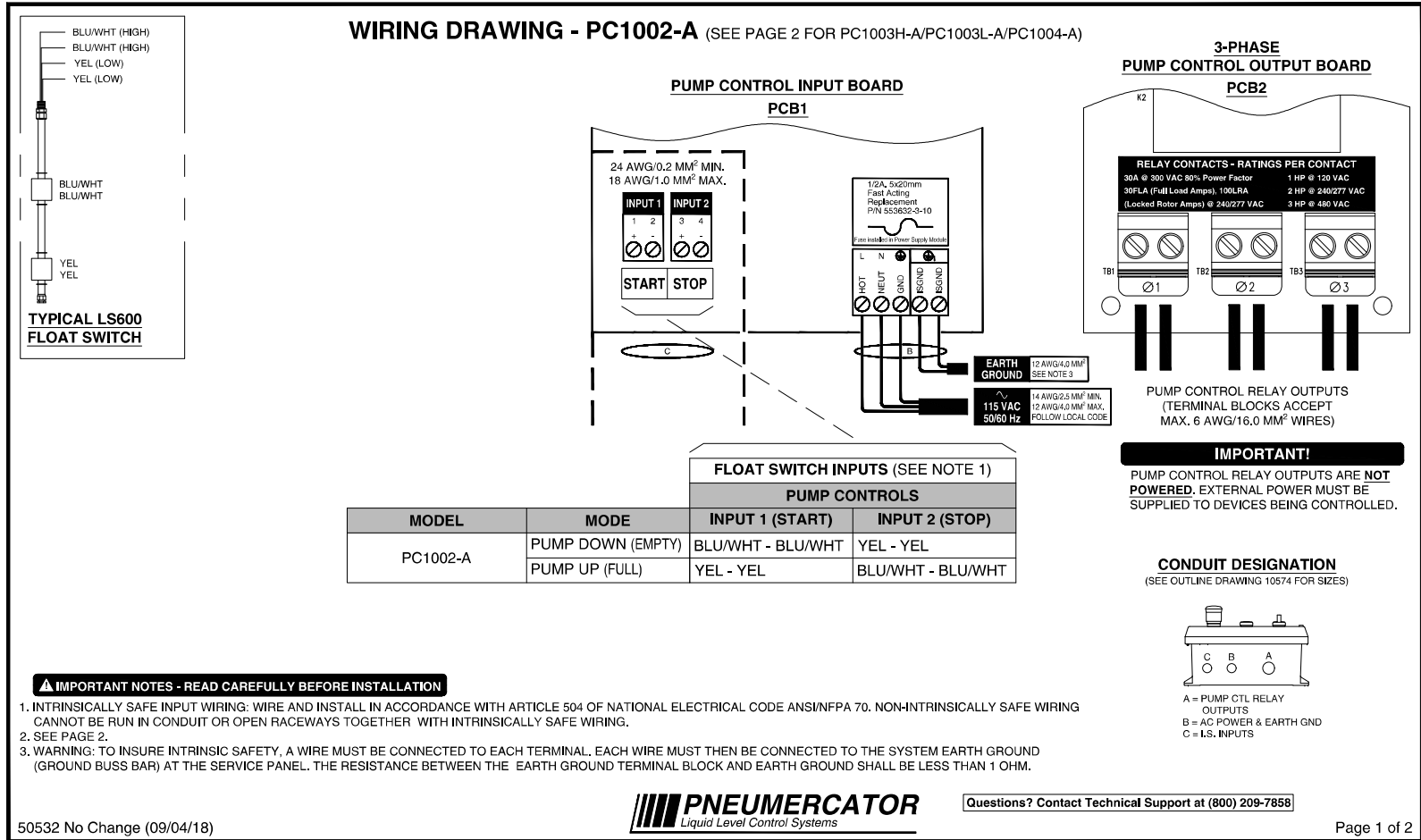
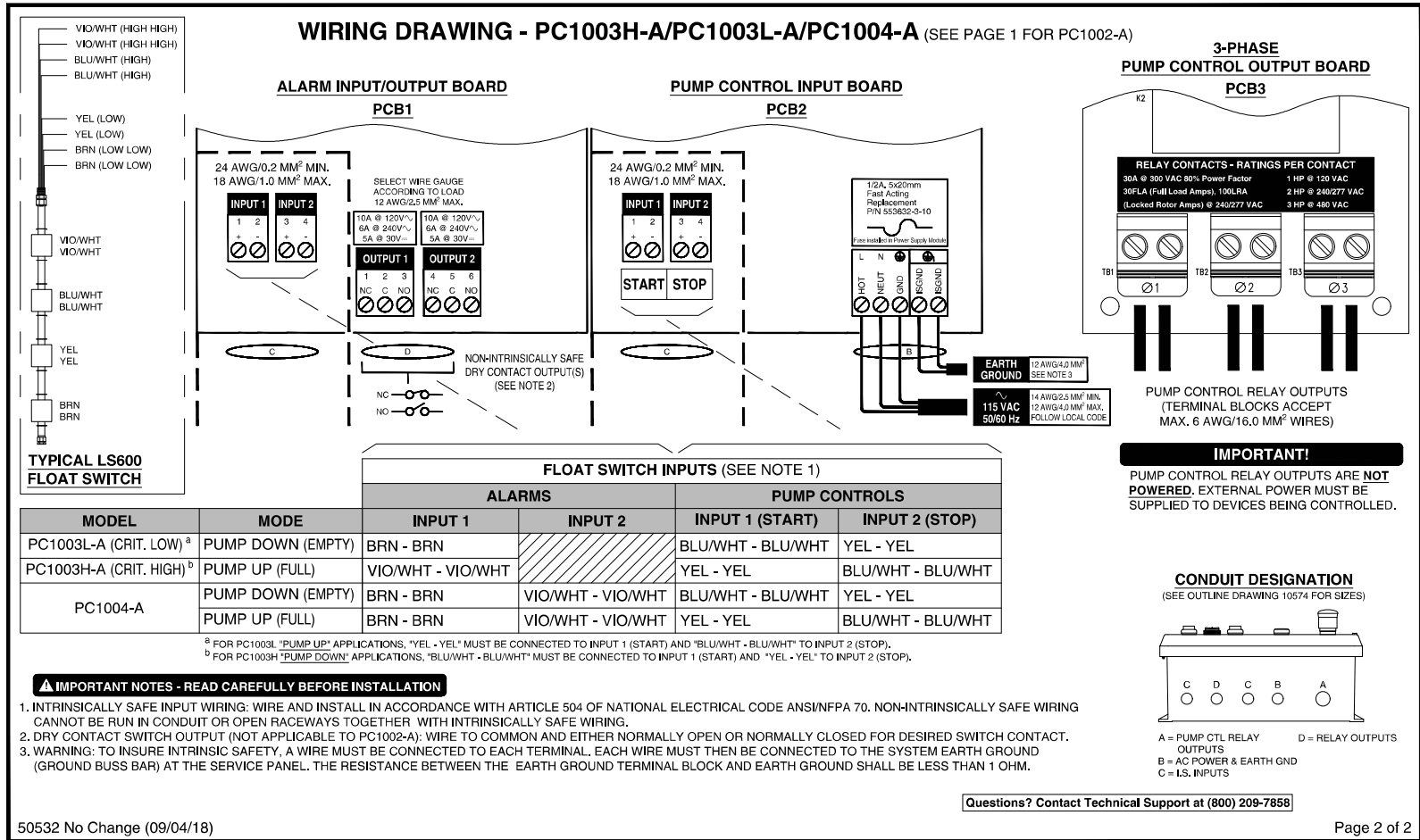

Figure 3-3 – PC1003-A / PC1004-A Wiring Diagram



FLOAT SWITCH INPUTS (SEE NOTE 1)					
MODEL	MODE	ALARMS		PUMP CONTROLS	
		INPUT 1	INPUT 2	INPUT 1 (START)	INPUT 2 (STOP)
PC1003L-A (CRIT. LOW) <sup>a</sup>	PUMP DOWN (EMPTY)	BRN - BRN		BLU/WHT - BLU/WHT	YEL - YEL
PC1003H-A (CRIT. HIGH) <sup>b</sup>	PUMP UP (FULL)	VIO/WHT - VIO/WHT		YEL - YEL	BLU/WHT - BLU/WHT
PC1004-A	PUMP DOWN (EMPTY)	BRN - BRN	VIO/WHT - VIO/WHT	BLU/WHT - BLU/WHT	YEL - YEL
	PUMP UP (FULL)	BRN - BRN	VIO/WHT - VIO/WHT	YEL - YEL	BLU/WHT - BLU/WHT

- IMPORTANT NOTES - READ CAREFULLY BEFORE INSTALLATION**
- INTRINSICALLY SAFE INPUT WIRING: WIRE AND INSTALL IN ACCORDANCE WITH ARTICLE 504 OF NATIONAL ELECTRICAL CODE ANS/NFPA 70. NON-INTRINSICALLY SAFE WIRING CANNOT BE RUN IN CONDUIT OR OPEN RACEWAYS TOGETHER WITH INTRINSICALLY SAFE WIRING.
  - DRY CONTACT SWITCH OUTPUT (NOT APPLICABLE TO PC1002-A): WIRE TO COMMON AND EITHER NORMALLY OPEN OR NORMALLY CLOSED FOR DESIRED SWITCH CONTACT.
  - WARNING: TO INSURE INTRINSIC SAFETY, A WIRE MUST BE CONNECTED TO EACH TERMINAL. EACH WIRE MUST THEN BE CONNECTED TO THE SYSTEM EARTH GROUND (GROUND BUSS BAR) AT THE SERVICE PANEL. THE RESISTANCE BETWEEN THE EARTH GROUND TERMINAL BLOCK AND EARTH GROUND SHALL BE LESS THAN 1 OHM.

Questions? Contact Technical Support at (800) 209-7858

9. Connect sensor wires to the PC1000-A INPUT TERMINALS following the matching diagram in Figures 3-2 through 3-5. The terminal blocks may be removed for ease of wiring by pressing down toward the conduit openings. Note that for PC1003/4 consoles, power need only be wired to the Pump Control Input Board. Maintain correct polarity between wires and respective terminal points.
10. Properly dress all wires inside the wiring sections and re-install the protective aluminum cover over the terminals.
11. Sensors should be logically identified as to location and type and recorded on the Sensor map provided in this manual, SECTION 3.3.

### **⚠ CAUTION**

**Sensor wires are to be connected ONLY to the designated input terminals of the INTRINSIC SAFETY compartment. DO NOT allow sensor wires to cross over into the non-intrinsically safe section. FAILURE TO COMPLY MAY RESULT IN PERSONAL INJURY, PROPERTY LOSS AND EQUIPMENT DAMAGE.**

### **⚠ CAUTION**

**Relay output terminals are located on the NON-INTRINSICALLY SAFE side of the console. ALL wiring to these terminals MUST enter through the designated conduit opening. Refer to FIGURE 1-4. FAILURE TO COMPLY MAY RESULT IN PERSONAL INJURY, PROPERTY LOSS AND EQUIPMENT DAMAGE.**

### 3.3 SENSOR MAP/SYSTEM SETUP

The sensor map/system setup below should be completed by the electrical installer as each sensor and control output function is wired to the PC1000-A system. This will provide the equipment operator a means of identifying each field device for proper system setup and use. The SENSOR MAP/SYSTEM SETUP should be adhered to or kept near the PC1000-A console.

#### SENSOR MAP/SYSTEM SETUP

CHNL	INPUT USAGE	SENSOR
Start		
Stop		
Alarm 1		
Alarm 2		

RELAY	ALARMS	USAGE
Alarm 1		
Alarm 2		

### 3.4 INSTALLATION AS A REMOTE PUMP CONTROL PANEL

The design of the PC1000-A allows this system to be used as a remote pump control panel to another system equipped with dry contact outputs. These outputs can be monitored by the PC1000-A so as to control the pump for the same condition as the main system has detected. If the PC1000-A is used in this application, then permanently remove the intrinsically safe (IS) cover by removing the two screws holding down the cover. This identifies this particular installation as a non-intrinsically safe application. Do not install intrinsically safe wires on an PC1000-A without the IS cover installed.

A single pair of wires per signal would connect the main system via the dry contact output to the PC1000-A on the Switch input.

All Pneumercator systems equipped with relay outputs are considered dry contact, or outputs without power. Other equipment manufacturers may use powered relay outputs. Consult the system manufacturer to determine if the system is equipped with outputs that are dry contact that can be used to represent the desired alarm condition.

#### ⚠ CAUTION

**DO NOT CONNECT POWER TO THE DRY CONTACT SENSOR INPUTS OF THE PC1000-A. FAILURE TO COMPLY MAY RESULT IN PERSONAL INJURY, PROPERTY LOSS AND EQUIPMENT DAMAGE.**

**SECTION 4 OPERATION**

**4.1 GENERAL**

The PC1000-A Pump Control System operates by latching on the Pump Control Load Relay when the Start input is true and will remain activated until the Stop input is true. A manual override switch is provided for on-demand control of the pump. This override switch will not activate the Pump if the Pump Stop signal is true. An Emergency Stop button is provided to disable the pump should a critical situation arise. The Emergency Stop button will need to be disengaged to resume normal site operation.

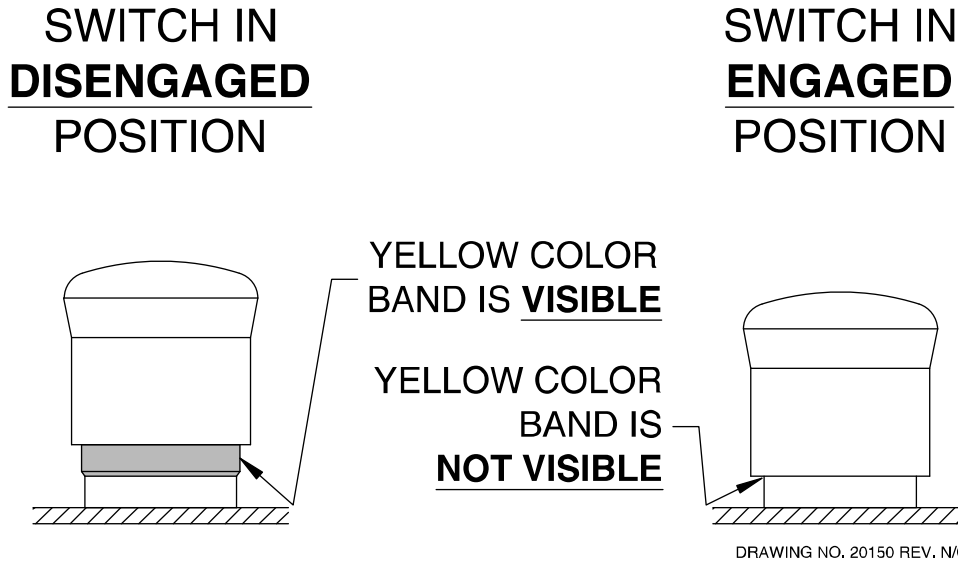

**Figure 4-1 – PC1000-A Emergency Stop Switch**

PC1003/4 systems provide input(s) for Critical High and/or Critical Low conditions. When an alarm is detected: a light comes on, a horn annunciates and a relay changes state. The horn may be silenced by pressing the RESET button, but the light will stay on and the relay will remain in the alarm state as long as the field sensor remains in the alarm condition, e.g., critical high liquid level. After the alarm condition is corrected, i.e., lowering the liquid level below the level switch setting, the alarm light will extinguish, the relay will return to its normal state, and the horn will automatically reset to the silent state. The behavior of the relay for the reset process can be changed to allow the relay to be returned to the normal state upon acknowledging the alarm (See section 3.1). On multiple sensor consoles, each input switch will actuate the horn and its respective light independent of the other sensor's state or the prior state of the alarm console. NOTE: The TEST button manually energizes the horn, all lights (except Pump On and AC), and all alarm output relays on the console. This is accomplished by simulating all inputs as being in the alarm state. If all inputs are in the alarm state PRIOR to pressing the TEST button, the TEST button will not have any function.

**4.2 HORN CONTROLS (PC1003/4 ONLY)**

In addition to silencing the horn by pressing the RESET button, the Loudness Level may be controlled by using a louver on the horn face from about 86 decibels to about 50 decibels.

## **SECTION 5 TROUBLESHOOTING**

### **5.1 GENERAL**

The On/Off switching control operation of the PC1000-A makes it simple to test and troubleshoot the system. Pressing the TEST button performs a functional test of the horn, Critical High, High, Low, and Critical Low indicator lights and all alarm relay contacts. Before pressing TEST, make sure all externally controlled devices are on standby or are accordingly addressed. Also, make sure that at least one input is not in alarm for the Test button to properly simulate all inputs being in alarm.

The input wiring can be disconnected to check the functioning of the inputs as well as to allow access to the wiring to perform a continuity test. If the wiring is disconnected, all of the lights are expected to turn off. To test the system, Use a jumper wire to simulate an open and closed state across the input and observe the behavior of the corresponding system light. A DC voltage measurement may be taken across the input to verify the presence of approximately 12VDC. If there is no voltage present with the wires disconnected from the input, then check the internal fuse with your ohmmeter while the AC power is shutoff from the circuit breaker.

To check the operation of the PC1000-A from a field wiring location, e.g., at the field sensor location, simply place a jumper wire between the field wire pair. This will activate the corresponding input within the PC1000-A. If this works as expected, then the wiring is intact.

All sensors can be tested with a continuity meter. By manipulating the float by hand, the state of the sensor changes and would be detected by the meter.

### **5.2 SPARE PARTS LIST**

<b>Description</b>	<b>Part #</b>
Annunciator (Horn)	553503-1
Fuse (0.5A Fast Acting, 5 x 20mm), 10-pack	553632-3-10
LED Assy (Green)	553636-2
LED Assy (Red)	553636-1
LED Assy (White)	553636-3
PC1003-A Alarm Input/Output Board (No Power Supply)	900899-3
PC1003-A Alarm Input/Output Board (No Power Supply) (w/ Intrinsically Safe Cover)	900910-3
PC1004-A Alarm Input/Output Board (No Power Supply)	900899-4
PC1004-A Alarm Input/Output Board (No Power Supply) (w/ Intrinsically Safe Cover)	900910-4
Pump Control Input Board (w/ Power Supply)	900899-5
Pump Control Input Board (w/ Power Supply and Intrinsically Safe Cover)	900910-5
Pump Control Output Board	900644-1

## **SECTION 6 MAINTENANCE/TESTING**

### **6.1 CONSOLE**

The operation of the PC1000-A alarm lights, horn, and alarm output relays can be verified by holding down the TEST button. The TEST button causes all alarm conditions for the system to go to the alarm state. For this reason, it is best to do this with at least one alarm condition in the normal state otherwise your horn will not activate since there are no new alarm conditions detected. If the lights and horn do not activate as expected, follow the troubleshooting instructions found in Section 5.

There are no consumables for the PC1000-A therefore no parts need to be changed on a regular basis. Refer to section 5 for a list of service parts available to repair the PC1000-A.

### **6.2 SENSORS**

The sensors themselves cannot be tested from the front panel of the PC1000-A. Instead the sensor must be removed and each float manipulated by hand to simulate an alarm condition. The only exception to this rule is in the case of the LS600 equipped with a test lever. This test lever allows for the testing of the uppermost float, typically used as the overfill protection. See Bulletin 193 for details on the LS600 Series sensors.

### **⚠ WARNING**

**Testing MUST be done by qualified personnel familiar with local wiring codes and explosion hazard electrical safety practices. FAILURE TO COMPLY MAY RESULT IN PERSONAL INJURY, PROPERTY LOSS AND EQUIPMENT DAMAGE.**

It is generally considered good practice to ensure that your system is fully operational on an annual basis. For thicker or more viscous liquids, inspect the system more frequently to confirm that no product has built up on the sensor so as to interfere with its proper operation. Your local regulations may require testing based on a different schedule so consult with your regulator/inspector for the frequency of testing needed for your application.





## WARRANTY

We warrant that our tank gauges, if installed according to instructions will be free from defects in material and workmanship for a period of one (1) year following the date of original shipment by us.

Our liability under this warranty shall be limited to, at our option,  
(i) repair of the defective tank gauge,  
(ii) replacement of the original tank gauge with new, or  
(iii) refund of the original purchase price;  
and, we shall not be liable for any labor, other installation costs, indirect or consequential damages, or other damages in connection with such gauge.

This constitutes our obligation and none other stated for any purpose except the above shall apply.

Contact Pneumercator for detailed warranty documentation.

REVISION 101008



Pneumercator Co.  
1785 Expressway Drive North  
Hauppauge, NY 11788  
TEL:(631) 293-8450 FAX:(631) 293-8533  
[www.pneumercator.com](http://www.pneumercator.com)

Distributed by: