

INSTALLATION MANUAL

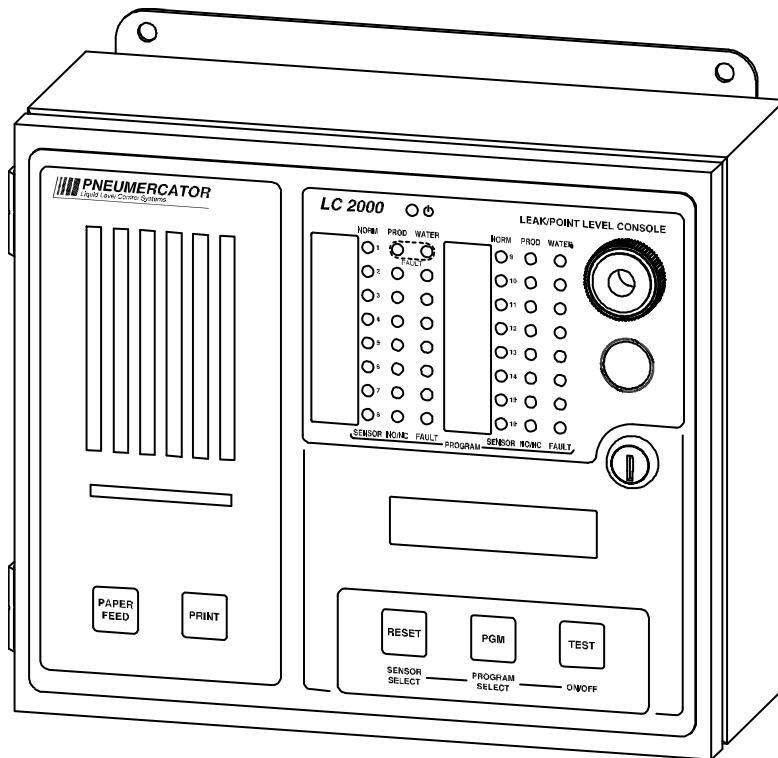

DRAWING NO. 20068 REV. N/C

MODEL LC2000

**© COPYRIGHT 2017 PNEUMERCATOR CO., INC.
1785 EXPRESSWAY DRIVE NORTH
HAUPPAUGE, NY 11788**

TEL: (631) 293-8450
FAX: (631) 293-8533
<http://www.pneumercator.com>

Note: A separate OPERATING MANUAL is available, but NOT required for LC2000 installation.

TABLE OF CONTENTS

		Page
	SAFETY INFORMATION	5
Section 1	PRODUCT DESCRIPTION	
1.1	General System Overview.....	6
1.2	Control Console.....	7
1.3	Liquid Leak Sensors.....	10
Section 2	INSTALLATION DETAILS	
2.1	Installation Checklist.....	13
2.2	Control Console Installation	14
2.3	Sensor Installation – General	16
2.3.1	Leak Sensor Installation – Steel Tanks and Vaulted Tanks	16
2.3.2	Leak Sensor Installation – Piping Sumps and Dispenser Pans.....	17
2.3.3	Leak Sensor Installation – Fiberglass Underground Tanks – Annulus.....	18
2.3.4	Leak Sensor Installation – Fiberglass Underground Tank Reservoirs	19
Section 3	WIRING INSTALLATION AND DIAGRAMS	
3.1	System Intrinsic Safety Wiring.....	21
3.2	Power Wiring	26
3.3	Sensor Wiring & Splices	27
3.4	Programmable Relay Outputs/Contact Closure Inputs.....	30
3.5	Data Communications Wiring.....	31
3.6	Carrier Insert Instructions	32
3.7	System Setup	33

⚠ IMPORTANT SAFETY INFORMATION

This manual contains instructions for installing electrical hardware in explosion hazard areas.

The following warnings must be considered to be in compliance with accepted codes.

Any inquiries about this manual, or to return defective equipment should be directed to:

**PNEUMERCATOR COMPANY
1785 EXPRESSWAY DRIVE NORTH
HAUPPAUGE, NY 11788
Attention: Technical Services
TEL: (631) 293-8450
FAX: (631) 293-8533
TOLL FREE: (800) 209-7858
www.pneumercator.com**

⚠ WARNING

Installation must be in strict accordance with this manual as adopted from the following codes:

- ISA RP12.6, "Installation of intrinsically Safe Instrument Systems in Class I Hazardous Locations."**
- UL - Underwriters Laboratories**
- NFPA 70, "National Electric Code."**
- NFPA 30A, "Automotive and Marine Service Station Code."**

FAILURE TO COMPLY MAY RESULT IN PERSONAL INJURY, PROPERTY LOSS AND EQUIPMENT DAMAGE.

⚠ WARNING

Alteration, modification or replacement with non-factory components could impair the intrinsic safety of this equipment, void the warranty and void the UL Listing. FAILURE TO COMPLY MAY RESULT IN PERSONAL INJURY, PROPERTY LOSS AND EQUIPMENT DAMAGE.

SECTION 1 – PRODUCT DESCRIPTIONS

1.1 GENERAL SYSTEM OVERVIEW

The LC2000 is a fully integrated secondary containment leak detection and point-level alarm system that will interface to all of the TMS series sensor model types, including discriminating and non-discriminating electronic or mechanical secondary containment leak sensors as well as single and multi-point level float sensors. The system is available with a capacity of 4, 8, 12 or 16 sensor inputs. Figure 1-1 shows a typical block diagram of how a system should be configured for installation, providing a general overview of the possible combinations of sensors, remote alarms and other optional equipment that may be required for the specific installation. Note that a detailed wiring diagram can be found in Section 3 of this manual.

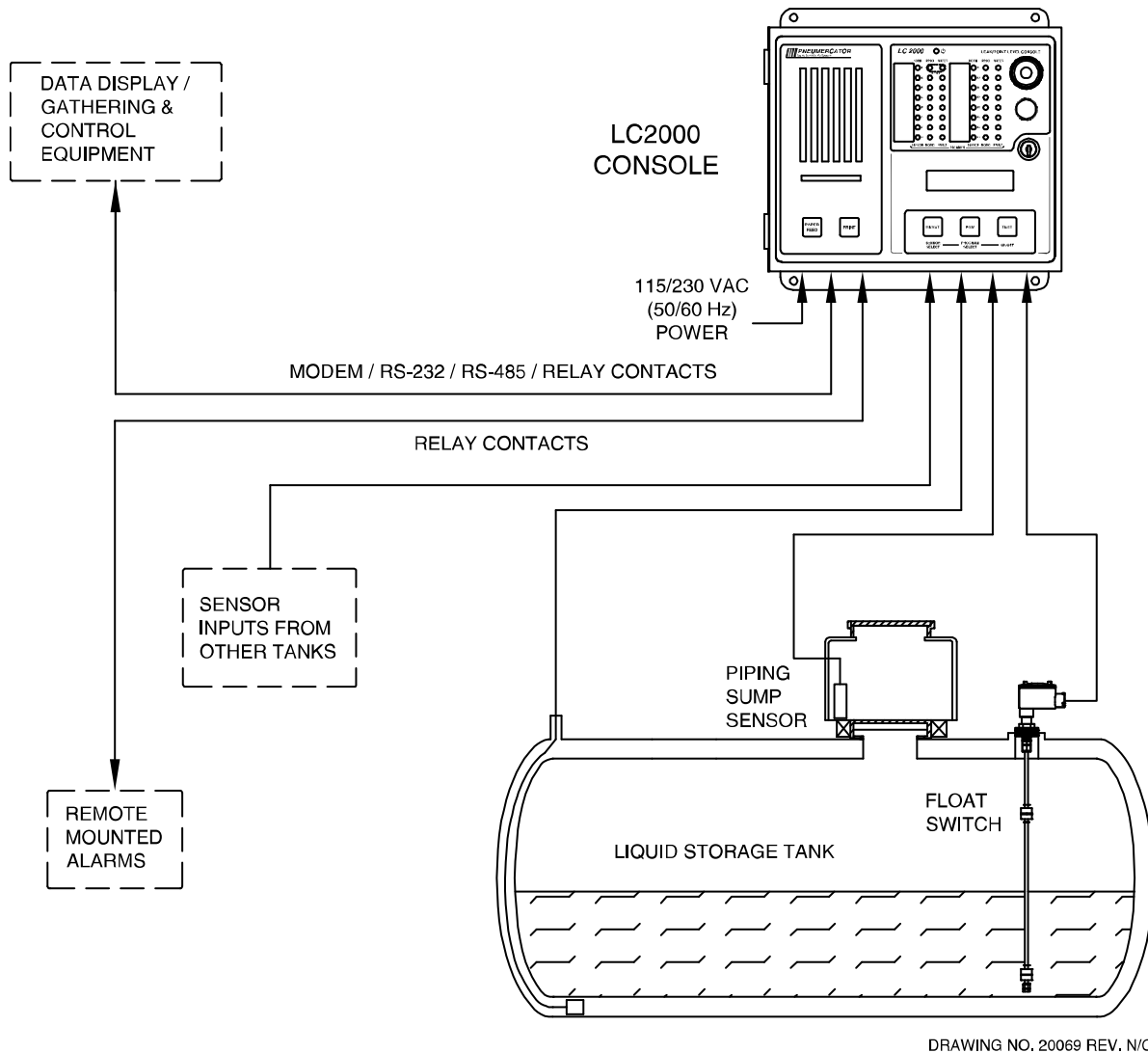

Figure 1-1 - Typical System Block Diagram

1.2 CONTROL CONSOLE DESCRIPTION

Figure 1-2 illustrates the standard LC2000 outline and dimensions. All standard configurations are equipped with either 4, 8, 12 or 16 sensor inputs, 1 RS-232 serial port, 1 RS-485 serial port, 2 Fully programmable relay outputs/2 dry contact closure inputs and NEMA 12 enclosure. Additional relays, printer and various communications option card(s) may also be installed.

The front panel of the LC2000 is available in four different configurations as listed below:

- LC2000-1... Console without display or printer
- LC2000-2... Console with display, no printer
- LC2000-3... Console with display and internal printer
- LC2000-4... Console with display and internal printer w/autowinder

⚠ WARNING

Installation MUST be done by qualified personnel familiar with local wiring codes and explosion hazard electrical safety practices. FAILURE TO COMPLY MAY RESULT IN PERSONAL INJURY, PROPERTY LOSS AND EQUIPMENT DAMAGE.

The standard LC2000 console enclosure is NEMA 12-rated for indoor installation. An optional NEMA 4/4X enclosure is available for outdoor installation. Confirm enclosure rating on the approval label located on the exterior, left-hand side of the enclosure before installation outdoors. See Figure 1-2 below for mounting flange locations and dimensions.

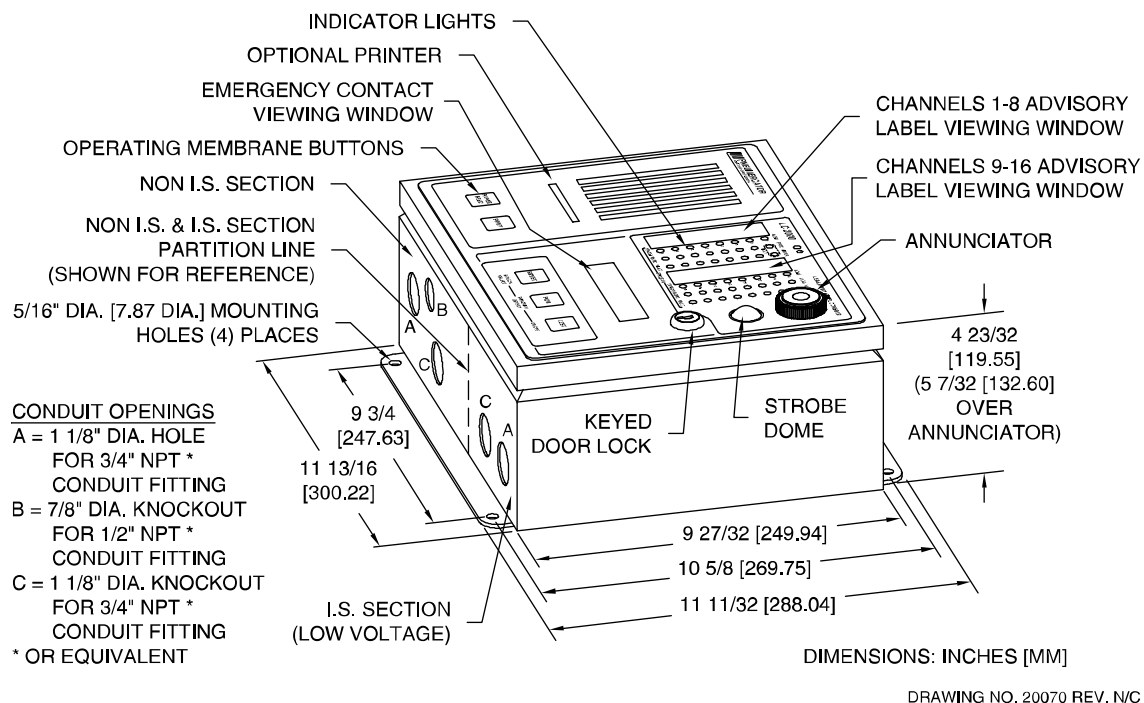

Figure 1-2 - LC2000 Console Outline

⚠ WARNING

The console is designed for Ordinary Location, Non-Hazardous installation only, as defined by Underwriters Laboratories (UL) and the National Electrical Code (NEC). DO NOT install where flammable vapors may be present. FAILURE TO COMPLY MAY RESULT IN PERSONAL INJURY, PROPERTY LOSS AND EQUIPMENT DAMAGE.

The console should be located in an area that is easily accessible to the personnel responsible for operation and maintenance of the system. Metal conduiting is recommended and may be required by local codes. All outdoor conduits must be watertight.

All conduit entries are provided on the bottom of the enclosure. Remove conduit knockouts only for those entries being used. If a knockout is removed but the entry will not be used, it must be sealed with an appropriate plug.

⚠ WARNING

Do not drill or modify enclosure. Use only knockouts provided. FAILURE TO COMPLY WILL VOID WARRANTY AND MAY PRESENT A SAFETY HAZARD RESULTING IN PERSONAL INJURY, PROPERTY LOSS AND EQUIPMENT DAMAGE.

⚠ WARNING

Conduit entries must only be used for their designated purpose in order to assure safe operation and to maintain safety certification. FAILURE TO COMPLY WILL VOID WARRANTY AND MAY PRESENT A SAFETY HAZARD RESULTING IN PERSONAL INJURY, PROPERTY LOSS AND EQUIPMENT DAMAGE.

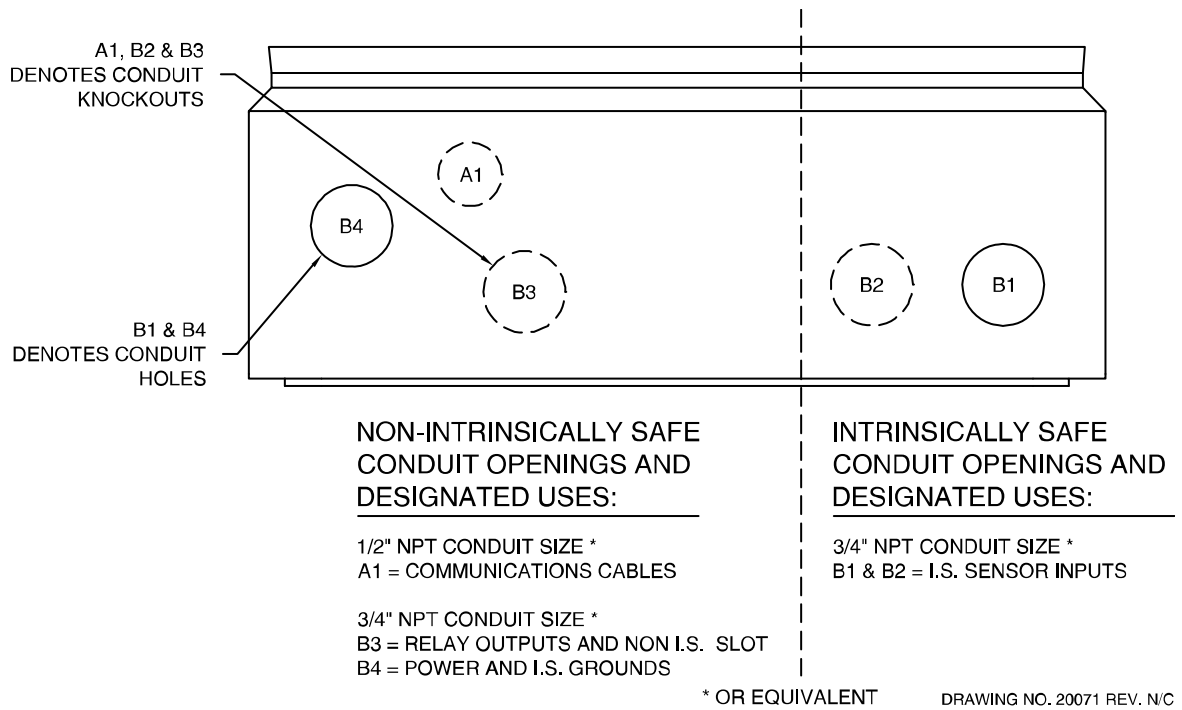

Figure 1-3 - LC2000 Designated Conduit Locations

1.3 AVAILABLE SENSOR TYPES

As described in Section 1.1, the LC2000 will interface to all of the TMS series sensor model types, including discriminating and non-discriminating electronic or mechanical secondary containment leak sensors as well as single and multi-point level float sensors. Figures 1-4 through 1-8 show five (5) typical sensor types offered by Pneumercator. Other non-Pneumercator mechanical types may be used; however, their use with LC2000 should be approved prior to attempting to wire them into the system.

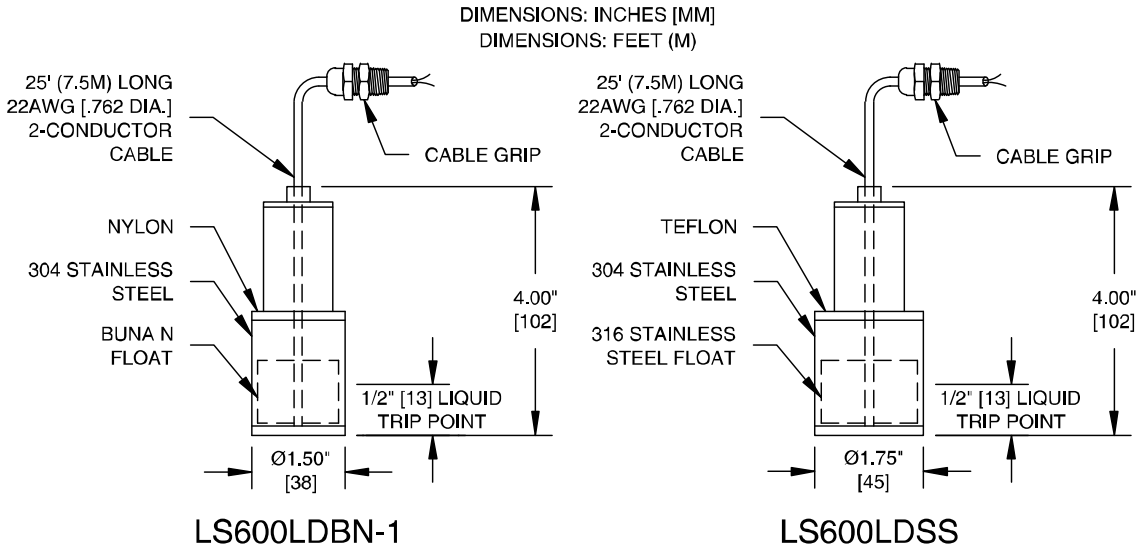
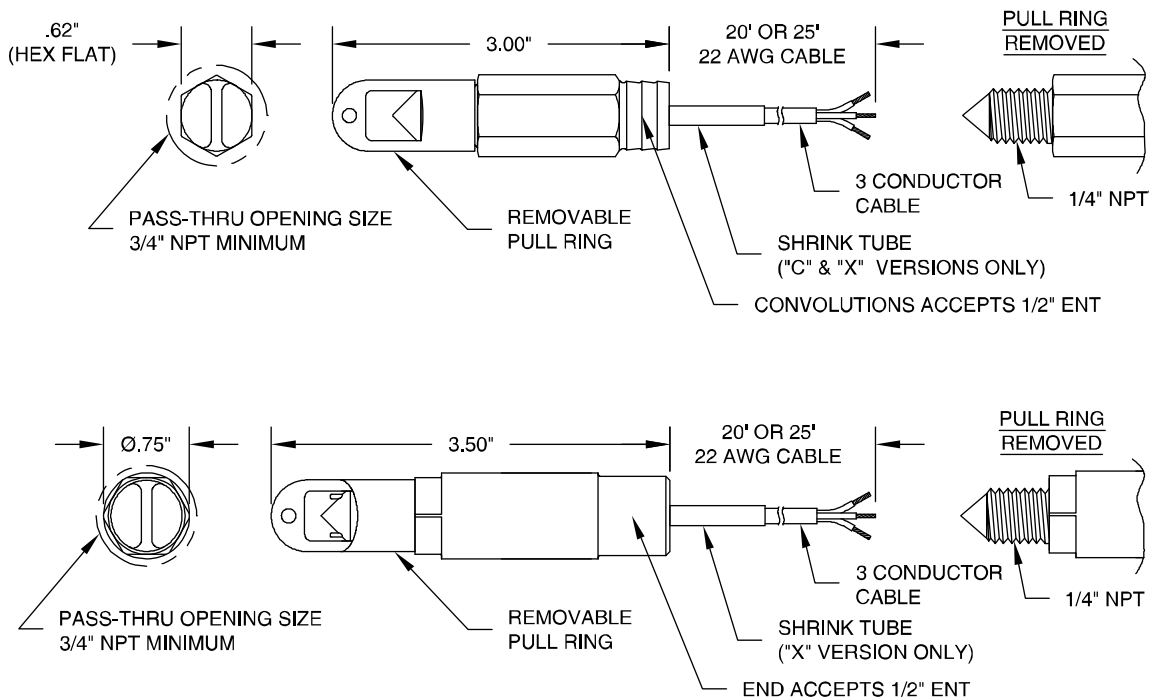

Figure 1-4 – LS600 LD Series



DRAWING NO. 20007 REV. B

Figure 1-5 – ES825 Series

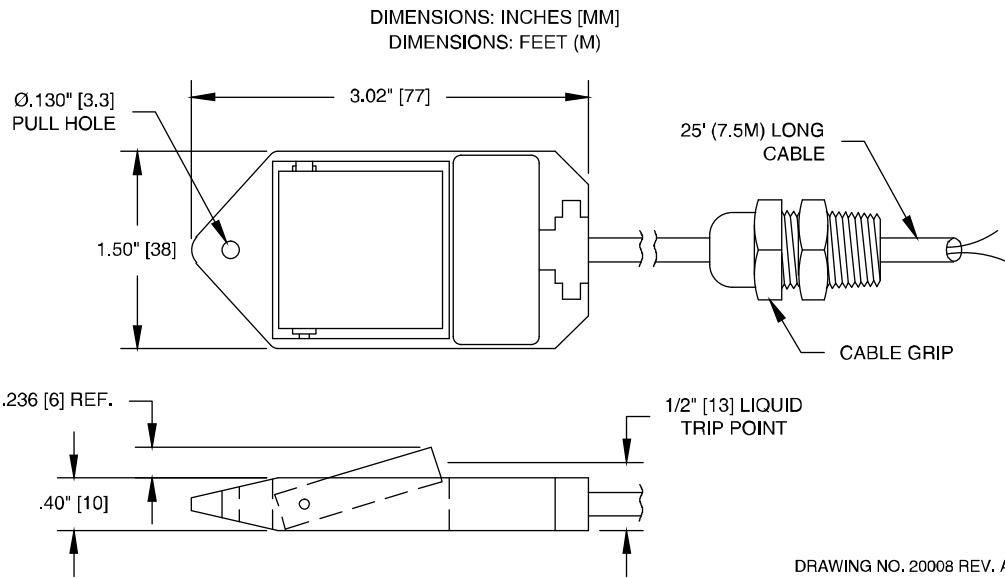

Figure 1-6 – LS610

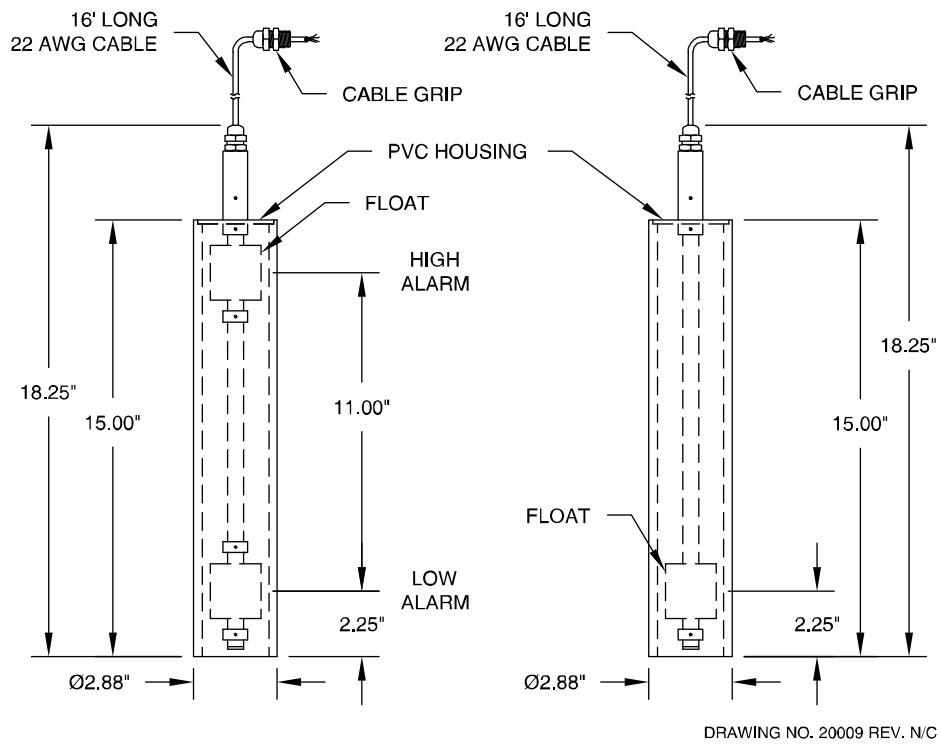
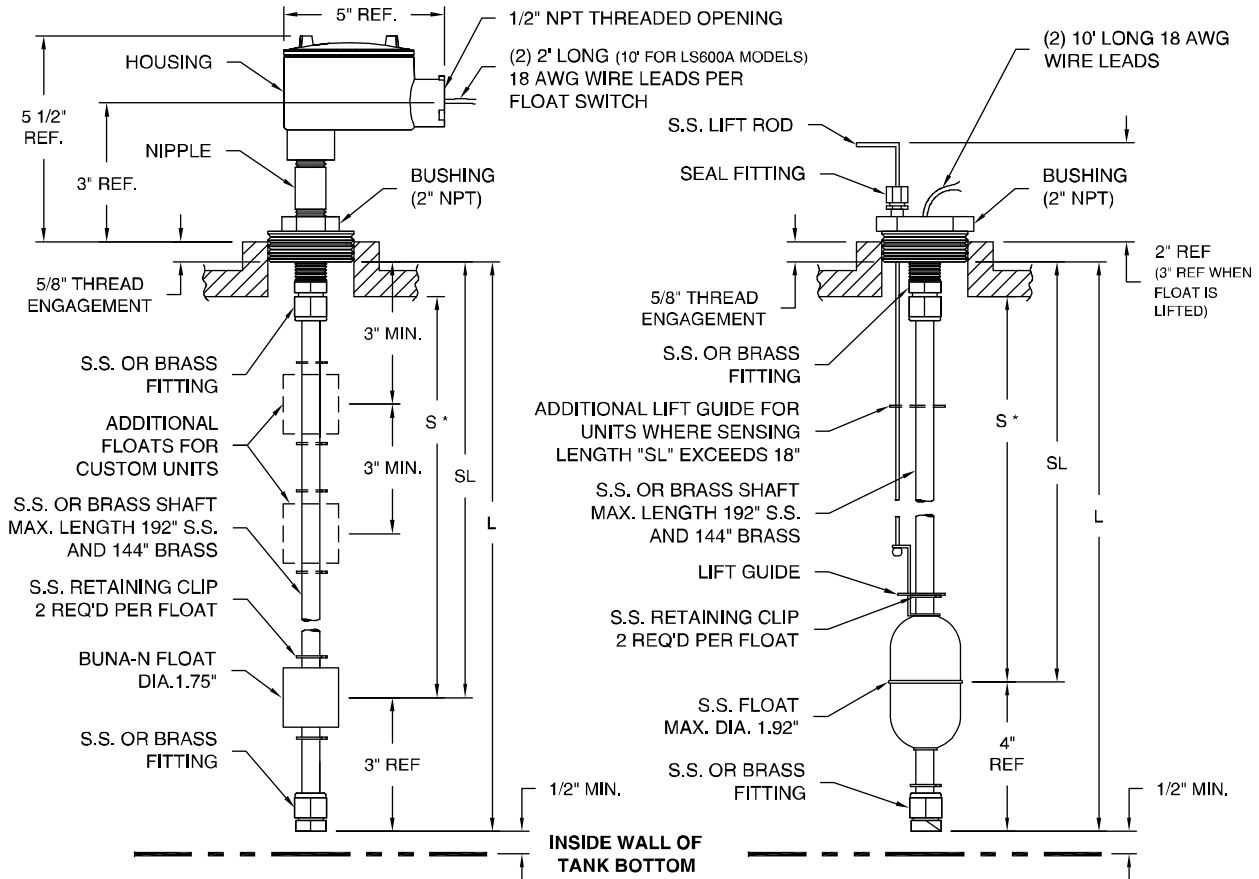

Figure 1-7 – RSU800

LS600, LS600 OW OR LS600A *

LS600A NCL



* LS600 OW SERIES SUPPLIED WITH STAINLESS FLOATS. HOUSING, NIPPLE & BUSHING NOT SUPPLIED ON LS600A SERIES.

NOTE
 CUSTOM MINIATURE LS600s ARE AVAILABLE FOR SUB BASE OR GENERATOR TANKS THAT REQUIRE SET POINTS TO BE CLOSER TOGETHER AND/OR TANKS WITH SMALLER THREADED OPENINGS. SEE OUTLINE DRAWING 10620.

OPTIONAL S.S. FLOAT FOR 2" OR 1 1/2" NPT OPENINGS
 MAX. DIA. 1.63"

DRAWING NO. 20057 REV. A

Figure 1-8 – LS600

SECTION 2 – INSTALLATION DETAILS

2.1 INSTALLATION CHECKLIST

⚠ WARNING

Do NOT apply power to the LC2000 until its installation has been checked and found to be in accordance with these instructions; National Electric Code; Federal, State and Local codes; and other applicable safety codes. FAILURE TO COMPLY MAY RESULT IN PERSONAL INJURY, PROPERTY LOSS AND EQUIPMENT DAMAGE.

The following points should be reviewed in preparation for installation, and again when installation is complete.

1. Review Figure 3-1 to ensure that all of the safety/wiring requirements have been met.
2. Check that all equipment at job site matches the DESIGN DRAWING SPECIFICATIONS for the tank sizes and control features required.
3. The console should be located as close as possible to the demarcation point of the hazardous area. **Never mount inside the hazardous area.**
4. POWER to the console should be properly wired to a DEDICATED 120/240 VAC CIRCUIT BREAKER. No other equipment can be powered from the same circuit breaker as the LC.
5. System cannot be connected to equipment that uses or generates more than 250 volts with respect to earth.
6. All LC2000 grounds must be terminated at the GND BUSS BAR in the same service panel as LC2000 power. A grounding rod, coldwater pipe or other connection should not be used. Refer to Figure 3-3 for illustrated details.
7. **Do not drill or modify enclosure.** Use only knockouts provided. Failure to comply will void warranty and may present a safety hazard.
8. I.S. cabling should be selected from the Cable Selection Chart in Figure 3-2. Each sensor wire/cable run SHOULD NOT EXCEED THE MAXIMUM DISTANCE RATING ON THE CABLE SELECTION CHART. Color-coding or numbering is highly recommended.
9. WATERPROOFING FIELD WIRE SPLICES using factory supplied splice kits is required for proper system operation.

2.2 CONTROL CONSOLE INSTALLATION

Console location should be selected for the operator's convenience, or as specified on the DESIGN DRAWINGS. DO NOT install the console in a hazardous-classified location.

⚠ WARNING

The console is designed for Ordinary Location, Non-Hazardous installation only, as defined by Underwriters Laboratories (UL) and the National Electrical Code (NEC). DO NOT install where flammable vapors may be present. FAILURE TO COMPLY MAY RESULT IN PERSONAL INJURY, PROPERTY LOSS AND EQUIPMENT DAMAGE.

Select a flat wall surface and prepare it with four wall-mounting inserts to accept up to 1/4-inch size bolts. Allow sufficient room for door to open and for conduit runs to enter ONLY THE CONSOLE BOTTOM. See Figure 1-2 for console dimensions.

Note that the console is divided into two electrical areas:

NON-INTRINSICALLY SAFE (LEFT SIDE)

for Power, Relay Control and Communications

INTRINSICALLY SAFE (RIGHT SIDE)

for Sensor Inputs

Figure 2-1 shows the console interior, again indicating intrinsically safe and non-intrinsically safe separation. **THIS SEPARATION MUST BE MAINTAINED.** Also, conduits containing sensor wiring may **NOT** be co-mingled with **ANY** other wiring, regardless of voltage. Refer to Section 3 for electrical conduit and wiring.

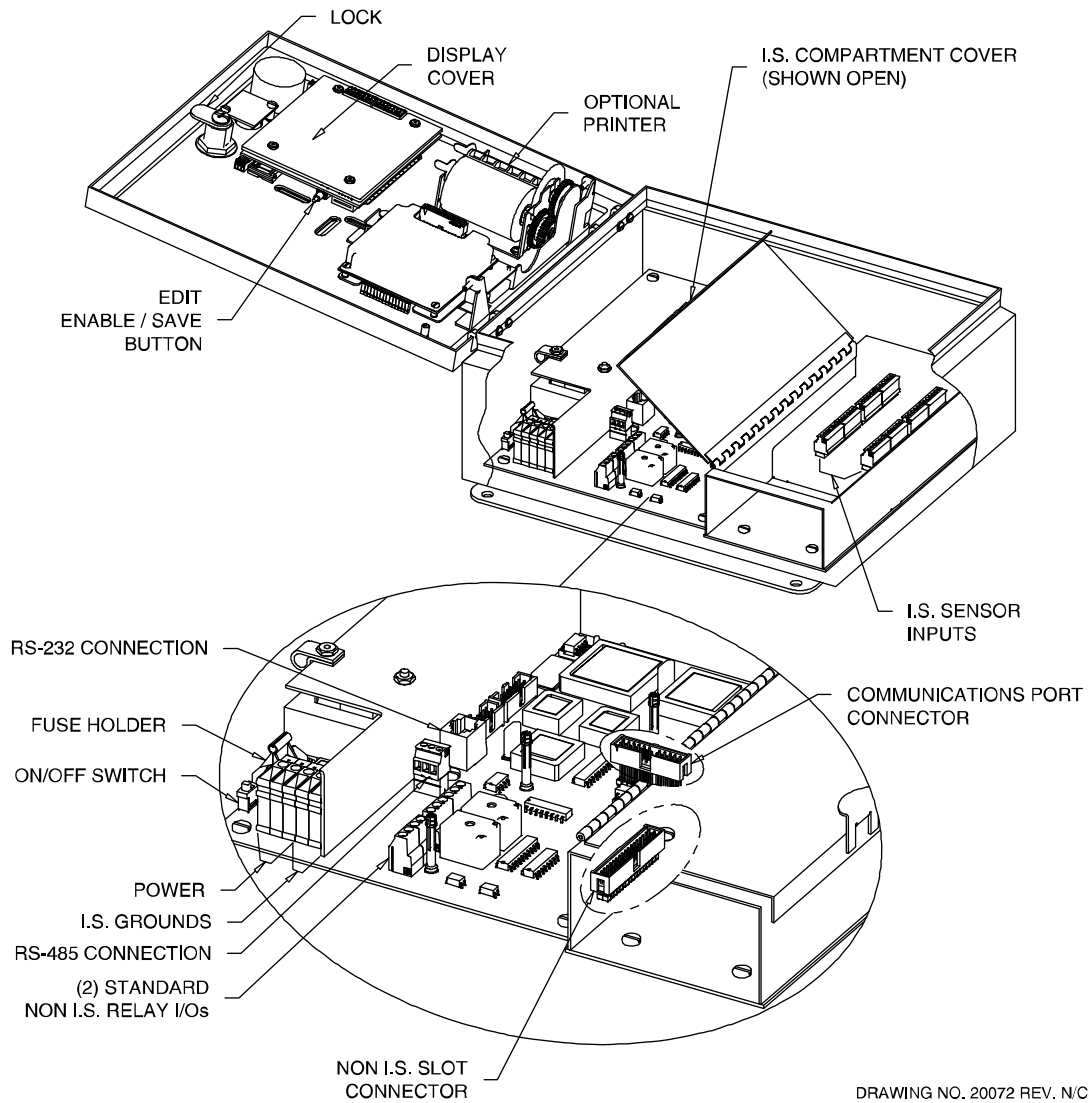

Figure 2-1 - Control Console Interior

2.3 SENSOR INSTALLATION - GENERAL

The interstitial or double-wall space of steel tanks and vaulted tanks as well as many other secondary containment areas can be fitted with either DISCRIMINATING or NON-DISCRIMINATING leak sensors. Also, for float type sensors, switch actuation may be factory set for either NORMALLY OPEN or NORMALLY CLOSED.

NOTE: For convenience, installation information for most sensors is provided in the following sections. However, it is recommended that the installer refer to the installation instructions provided with each sensor for more detailed or possibly more current information.

2.3.1 LEAK SENSOR INSTALLATION IN STEEL AND VAULTED TANKS

Check the specific design drawings for the job, or choose the sensor type desired from Figures 1-4 and 1-5. Install sensor per Figure 2-2 as follows:

1. Remove the watertight CORD CONNECTOR supplied by sliding it off the sensor cable.
2. Thread the watertight CONNECTOR into the top of a 2" by 1/2" reducer bushing or monitor pipe cap pre-tapped for a 1/2" NPT hole. (The use of any standard monitor cap from 2" to 4" pipe size is recommended. The cap or reducer bushing IS NOT SUPPLIED with the sensor and must be provided by the installer).
3. Measure the "MOUNTING HEIGHT" from top to bottom of monitoring pipe.
4. Feed the sensor cable through the watertight CONNECTOR from the BOTTOM SIDE of the REDUCER (or CAP) fitting to a cable length suitable for the MOUNTING HEIGHT; or to allow sensor to rest on the monitor pipe bottom; or as required by local codes. Cable may be cut or extended to proper length.
5. Re-tighten the CORD CONNECTOR to fix the sensor cable length.
6. Mate the REDUCER or CAP to the top of the monitor pipe. Tighten the CONNECTOR to ensure a WATERTIGHT SEAL.
7. Route the sensor cable to the junction box and complete the wiring installation in accordance with Section 3.

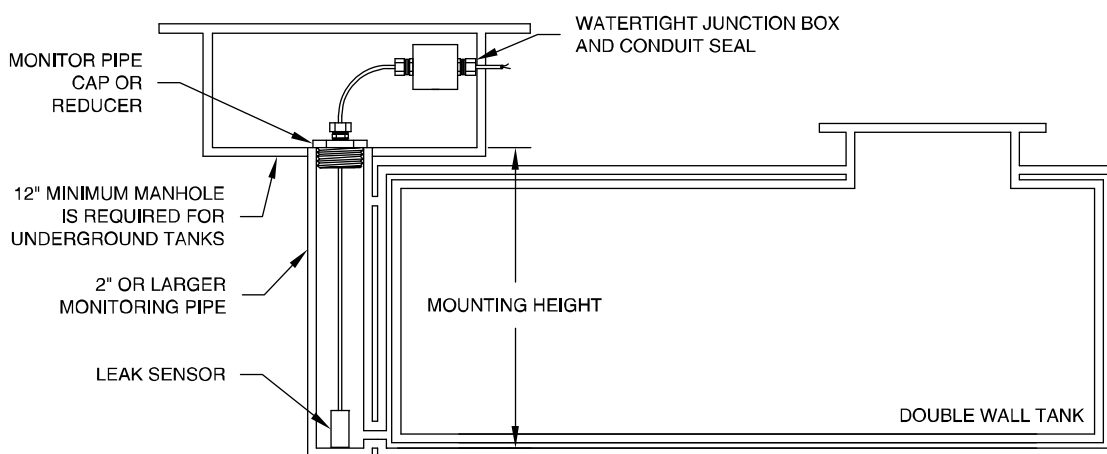

DRAWING NO. 20016 REV. C

Figure 2-2 - Leak Sensor Installation - Steel Vaulted Tanks

2.3.2 LEAK SENSOR INSTALLATION IN PIPING SUMPS AND DISPENSER PANS

Check the specific design drawings for the job, or choose the sensor type desired from Figures 1-4 and 1-5. Install sensor per Figure 2-3 as follows:

1. Measure the "MOUNTING HEIGHT" from conduit or junction box to the bottom of the SUMP (or MANHOLE, VAULT or DISPENSER PAN).
2. Feed the sensor cable through the watertight CONNECTOR to length suitable for the MOUNTING HEIGHT; or to allow sensor to rest on the containment bottom; or as required by local codes. Feed an additional 12 inches past the CONNECTOR for splicing inside the junction box; cable may be cut to proper length.
3. Thread the CONNECTOR into the WATERTIGHT JUNCTION BOX and tighten the CONNECTOR cord grip over the cable to insure a WATERTIGHT SEAL. The sensor should rest on the containment floor or as required by local codes.
4. Complete the wiring installation in accordance with Section 3.

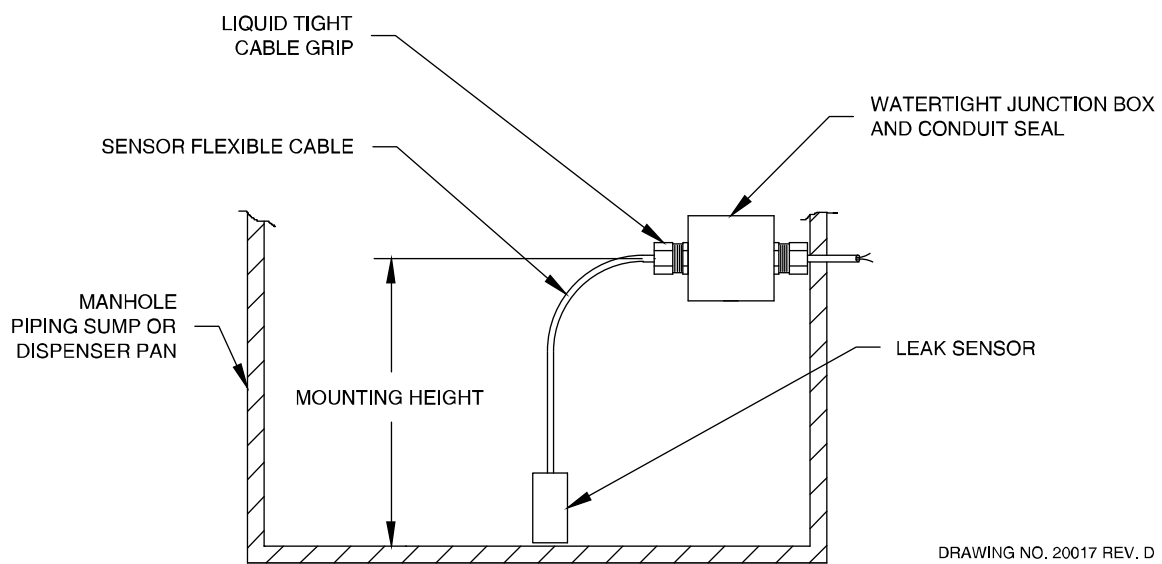

Figure 2-3 - Leak Sensor Installation in Piping Sumps, Manholes, and Dispenser Pans

2.3.3 LEAK SENSOR INSTALLATION IN FIBERGLASS TANK ANNULUS

The annular space of fiberglass tanks can be fitted with either a "DRY ANNULUS" type sensor, models ES825 (Figure 1-5) and LS610 (Figure 1-6), or a "WET RESERVOIR" sensor model RSU800 (Figure 1-7). The wet reservoir is also referred to as the HYDROSTATIC METHOD. Check the specific design drawings for the job, or choose the type sensor desired from Figures 1-5 through 1-7. Install sensor per Figures 2-4 or 2-5.

Instructions per Figure 2-4, DRY ANNULUS SENSOR:

1. Calculate the sensor cable's MOUNTING LENGTH from tank size data so the sensor rests at tank bottom; or use the following method.

Determine the cable's MOUNTING LENGTH by adding the cable measurement M from the table at the right to the RISER HEIGHT. Mark the cable at that length. **DO NOT CUT THE CABLE.**

CABLE MEASUREMENT FROM END OF SENSOR	
Tank Dia.	Cable M
4 Feet	81 in.
6 Feet	118 in.
8 Feet	150 in.
10 Feet	194 in.
12 Feet	222 in.

2. Remove the watertight CORD CONNECTOR supplied by sliding it off the cable.
3. Thread the CONNECTOR into the top of a 2" by 1/2" reducer bushing or riser pipe cap pre-tapped for a 1/2" NPT hole. (The use of any standard monitor cap from 2" to 4" pipe size is recommended. The cap or reducer bushing IS NOT SUPPLIED with the sensor and must be provided by the installer).
4. At riser top, attach the annular space PULL CORD (this is part of the tank supplier's pre-installed accessories) to the sensor's PULL HOLE.
5. Pull the free end of the PULL CORD out of the riser while feeding the sensor into the riser and through the annular space until the sensor is at the bottom centerline of the tank. The MOUNTING LENGTH MARK should be about 5 INCHES above the open riser. Adjust its position as necessary and, without disconnecting the PULL CORD, coil its excess inside the riser pipe.
6. Feed the sensor cable through the BOTTOM of the riser cap (or bushing), and through the CORD CONNECTOR while positioning cap over the riser pipe. Mate riser and cap.
7. Tighten CONNECTOR over the cable to ensure a WATERTIGHT SEAL.
8. Complete the wiring installation in accordance with Section 3.

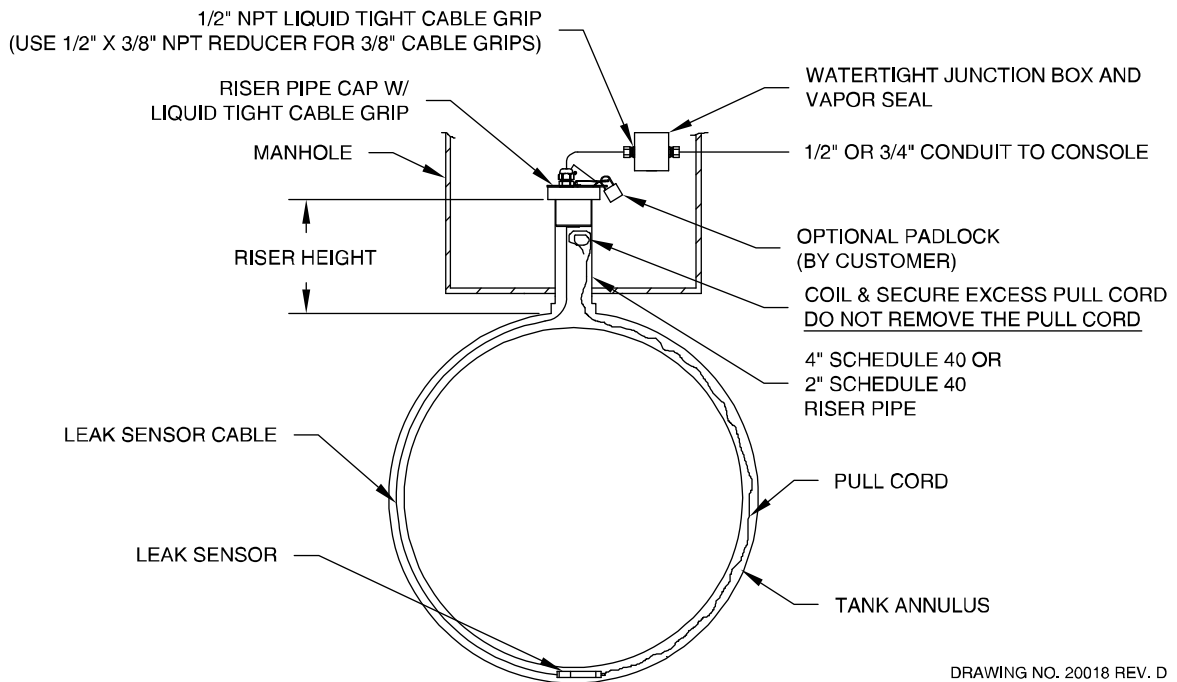

DRAWING NO. 20018 REV. D

Figure 2-4 - Dry Leak Sensor Installation in Fiberglass Tanks

2.3.4 HYDROSTATIC LEAK SENSOR INSTALLATION IN FIBERGLASS TANK RESERVOIRS

The model RSU800 sensor uses a dual float that senses a HIGH and LOW liquid level within the reservoir. If a tank leak occurs through either wall of the DOUBLE-WALL tank the liquid level in the reservoir changes. When it reaches the upper or lower limits of the sensor a contact closure is transmitted to the control console.

Instructions per Figure 2-5, HYDROSTATIC LEAK SENSOR:

1. The tank reservoir should be fitted with a 4 inch RISER PIPE and CAP, supplied by THE INSTALLER. The riser should be at least 12 inches long as measured from the reservoir opening. The riser cap may be any standard type, but as a minimum it should have a 3/8" NPT tapped hole to accept the CORD GRIP CONNECTOR SUPPLIED BY PNEUMERCATOR, or contain its own suitable cord grip. (An alternate method is to drill and tap the wall of the riser pipe). The use of a riser cap with a VENT TUBE is only recommended where local installation requires one.
2. If the riser cap does not contain its own cord connector, thread the PNEUMERCATOR SUPPLIED CONNECTOR into the tapped hole using sealing compound as required. (Alternately, the CONNECTOR may be threaded into the sidewall of the riser).
3. Slowly lower the sensor into the riser until it rests on the reservoir bottom. The top portion should extend into the riser pipe for support from tipping over. The liquid level in the reservoir should be at about 7 inches up the sensor's height for optimum performance. (See Figure 1-7 for float travel set point limits).

4. Feed the sensor cable through the **BOTTOM** of the riser cap (or pipe wall), and through the **CORD CONNECTOR**. Leave just enough slack inside the riser pipe so the sensor remains on the bottom, and will not tip over.
5. Mate the riser and cap; tighten the **CONNECTOR** over the cable to ensure a **WATERTIGHT SEAL**.
6. Complete the wiring installation in accordance with Section 3.

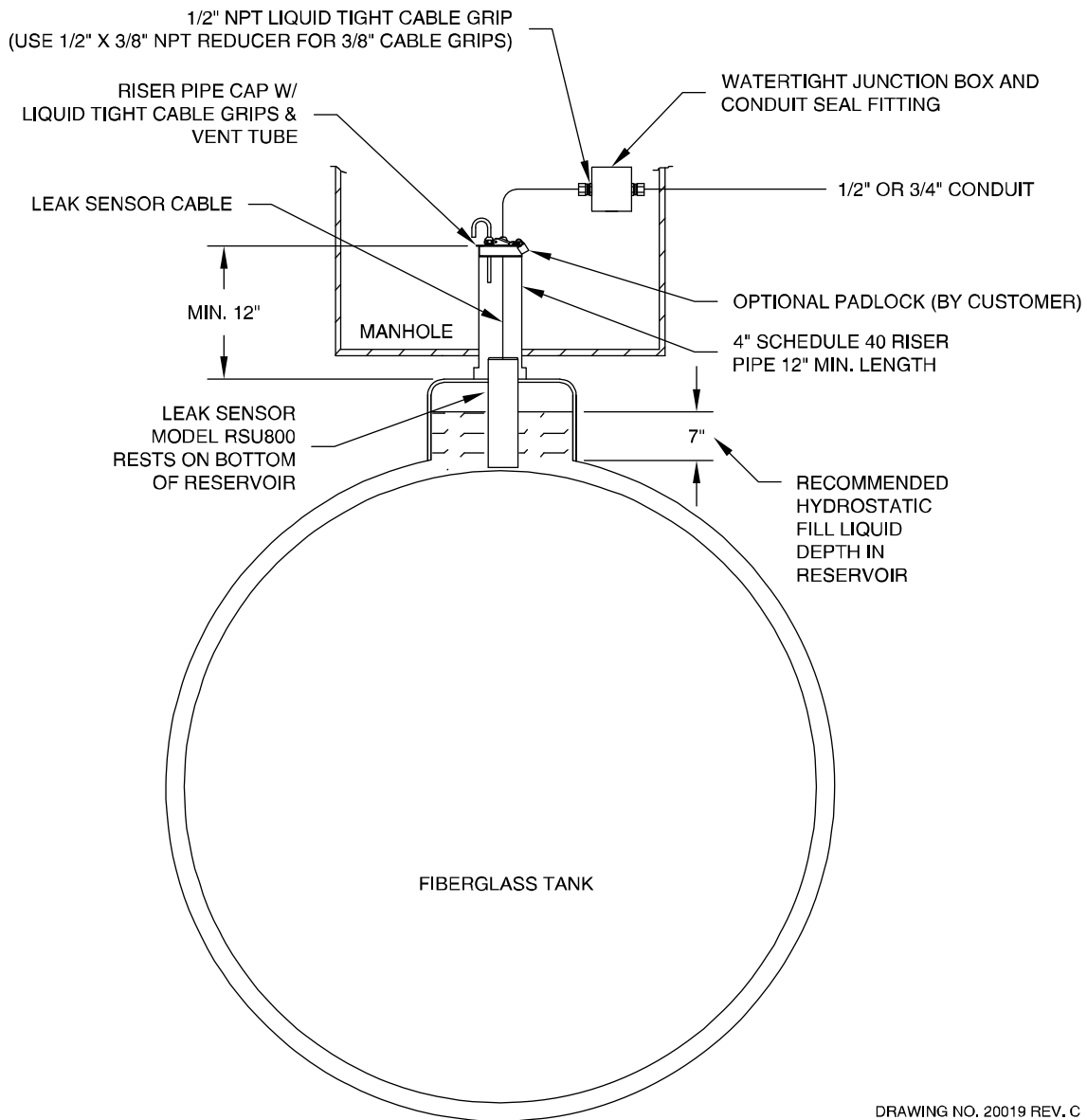

Figure 2-5 - Hydrostatic Leak Sensor Installation in Fiberglass Tanks

SECTION 3 – WIRING INSTALLATION AND DIAGRAMS

⚠ CAUTION

Sensors connected to the LC2000 are usually installed in explosion hazard areas typical of liquid hydrocarbon fuel tanks. For these applications, it is CRITICAL that electrical conduit and wiring be installed by qualified installers familiar with all provisions of the National Electrical Code relating to equipment intended for use in EXPLOSION HAZARD areas. The primary concern is to maintain physical separation between intrinsically safe and non-intrinsically safe wiring by running separate conduit attached to the control console at the designated knockouts. ALL conduits carrying sensor wiring into the hazardous area MUST be fitted with standard vapor seal-off fittings at all field junction boxes and again where the conduit first enters the non-hazardous area. FAILURE TO COMPLY MAY RESULT IN PERSONAL INJURY, PROPERTY LOSS AND EQUIPMENT DAMAGE.

3.1 SYSTEM INTRINSIC SAFETY WIRING (SENSOR WIRING)

Figure 3-1 illustrates wiring installation requirements that must be followed in order to establish and maintain an intrinsically safe installation. Careful attention must be given to maintaining mechanical segregation between intrinsically safe and non-intrinsically safe wiring throughout the installation.

SENSOR WIRING INSTALLATION. Refer to Figures 1-4 through 1-8 for console conduit openings and specific sensors that will be wired into the LC2000 system. Install wiring as follows:

1. It is recommended that the conduit runs be mapped out prior to installation for best efficiency. The LC2000 provides two $\frac{3}{4}$ " knockouts, each designated for up to eight (8) sensor cables. Rigid conduit is recommended, but local codes may have less stringent requirements.

⚠ CAUTION

All LC2000 sensor wiring may be run in the same conduit. NO OTHER WIRING MAY BE RUN IN THESE CONDUITS. FAILURE TO COMPLY MAY RESULT IN PERSONAL INJURY, PROPERTY LOSS AND EQUIPMENT DAMAGE.

2. At appropriate locations along the conduit runs (see Figures 2-2 through 2-5) install watertight couplings and approved VAPOR SEAL-OFF fittings.
3. At each sensor location install a WATERTIGHT ELECTRICAL JUNCTION BOX. Allow enough room around the sensor tank fitting for proper installation of the sensor and all conduit/junction box fittings, and for later removal if necessary.
4. Attach the conduit at the LC2000 console ONLY to one of the two $\frac{3}{4}$ " conduit knockouts located on the bottom RIGHT SIDE designated for the sensors. Use NEMA 4 weathertight fittings for outdoor locations.

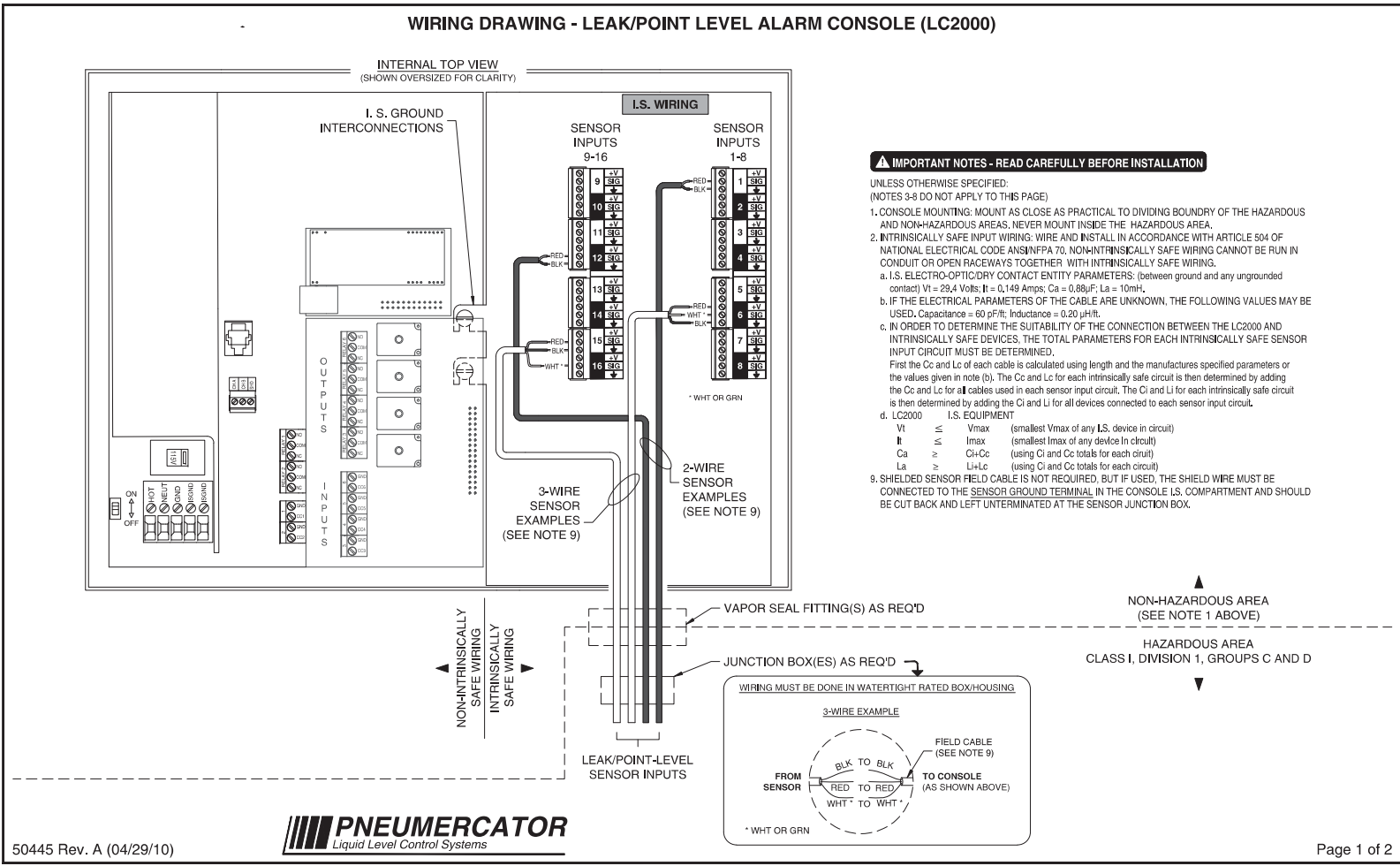

Figure 3-1a - Intrinsically Safe Wiring Diagram

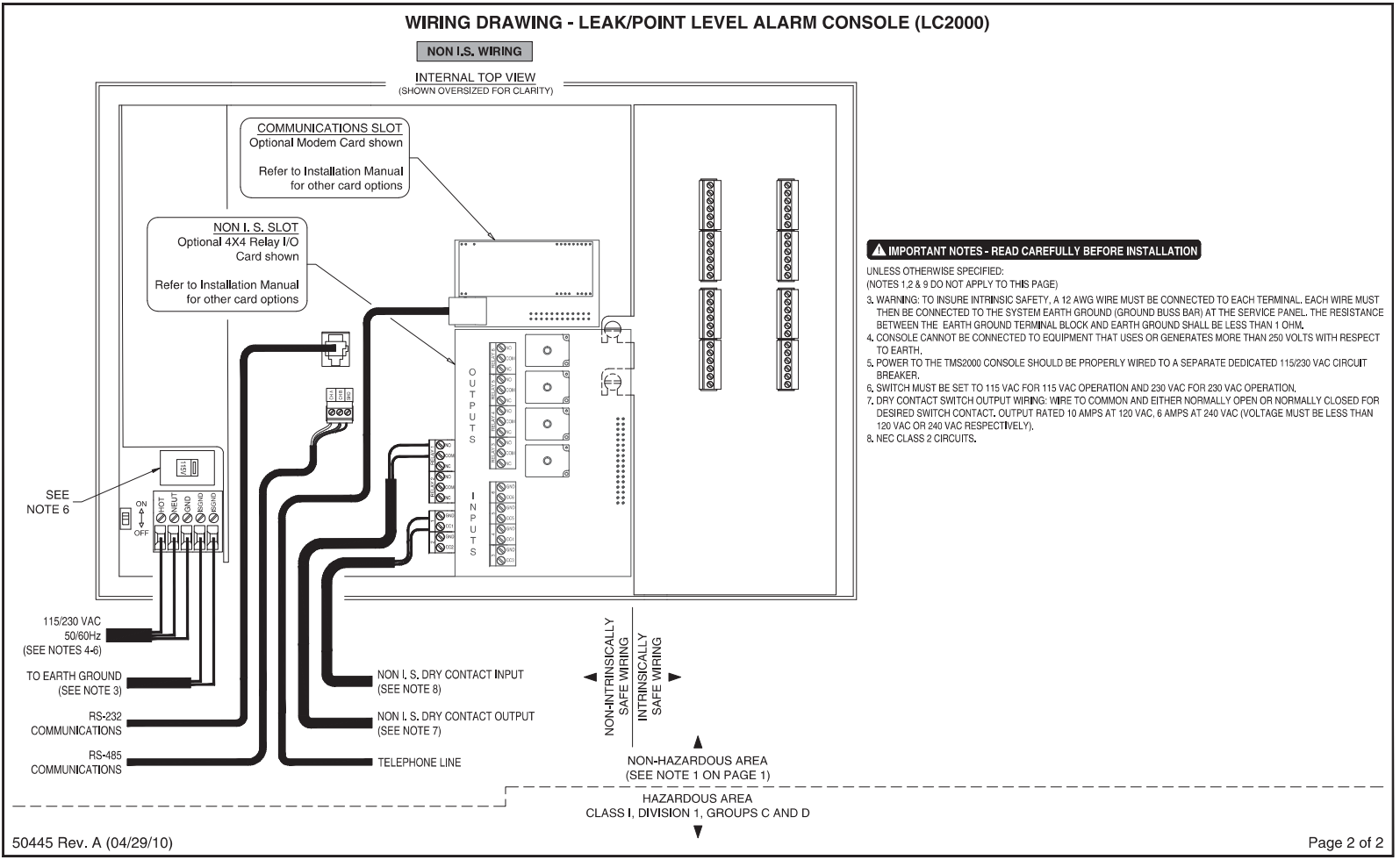

Figure 3-1b – Non-Hazardous Wiring Diagram

CABLE SELECTION GUIDE FOR INTRINSIC SAFETY

TYPE <small>(SEE NOTE 2)</small>	MANUFACTURERS			GROUP C		GROUP D	
	BELDEN	ALPHA	COLOR CODE	TOTAL LENGTH FEET <small>(SEE NOTE 3)</small>	CHANNEL MAXIMUM LENGTH FEET <small>(SEE NOTE 4)</small>	TOTAL LENGTH FEET <small>(SEE NOTE 3)</small>	CHANNEL MAXIMUM LENGTH FEET <small>(SEE NOTE 4)</small>
	3-WIRE OPTO-SENSOR ES825 series, ES820-100 (ELS-1100)						
NS	8443	1173C	BLK / RED / GRN (BELDEN) BLK / RED / WHT (ALPHA)	2700	2700	11300	5500
S	9608	6327	BLK / RED / WHT	2600	2600	11000	5500
S	-	2403C	BLK / RED / WHT	3800	3800	16000	5500
S, B	83553	-	BLK / RED/WHT	2700	2700	11000	5500

Figure 3-2 - Intrinsically Safe Cable Selection Guide

NOTES:

- 1.) ALL CABLES SPECIFIED HAVE A NOMINAL PAIR INDUCTANCE OF 0.2uH/FT.
- 2.) TYPE SPECIFIERS
 NS = NON-SHIELEDDED
 S = SHIELEDDED
 B = DIRECT BURIAL (IF ALLOWABLE PER LOCAL CODES)
- 3.) TOTAL LENGTH:

LEAK SENSORS - TOTAL COMBINED CABLE LENGTH FOR ALL LEAK SENSORS

- 4.) CHANNEL MAXIMUM LENGTH: MAXIMUM CABLE LENGTH PER SENSOR.

- 5.) FOR OPTO-SENSORS, SHIELEDDED CABLE IS NOT REQUIRED, BUT IF USED IN THE APPLICATION, THE SHIELD MUST BE CONNECTED TO "SHD" TERMINAL IN CONSOLE I.S. COMPARTMENT.

5. Pull properly marked 2 or 3 conductor cable (depending on sensor requirements) for each sensor through the conduit leaving at least 24 inches excess at both console and junction box ends for final connections. The field wires must be resistant to hydrocarbon liquids; type THHN or MTW, 22 AWG is recommended.
6. Fill all conduit VAPOR SEAL-OFF FITTINGS with approved filling compound and tighten all conduit fittings.
7. Splice all sensor wires to the respective conduit wires at each WATERTIGHT JUNCTION BOX. (See Figure 3-4 for a recommended procedure). Maintain correct color-coding and polarity between wires.
8. Connect sensor wires to the LC2000 INPUT TERMINALS following Figure 3-1. Maintain correct polarity between wires and respective terminal points.
9. Sensors should be logically identified as to location and type and recorded on the sensor map provided in this manual, SECTION 3.6.

⚠ CAUTION

Sensor wires are to be connected ONLY to the designated input terminals of the INTRINSIC SAFETY compartment. Do NOT allow sensor wires to cross over into the non-intrinsically safe section. FAILURE TO COMPLY MAY RESULT IN PERSONAL INJURY, PROPERTY LOSS AND EQUIPMENT DAMAGE.

3.2 POWER WIRING INSTALLATION

1. Confirm that the 115/230 VAC selector switch in the LC2000 is set correctly.
2. The LC2000 **MUST** be wired to a dedicated circuit breaker for intrinsically safe applications. This is an NEC code requirement for intrinsically safe apparatus. Wire in accordance with Figure 3-3 LC2000 AC WIRING.
3. The TWO (2) Intrinsically Safe (IS) grounds designated on the AC terminal block **MUST** be connected to EARTH GROUND at the service panel providing AC power. Connection must be made using 12AWG wiring providing a resistance to ground no greater than 1 ohm. Refer to Figure 3-3 LC2000 AC WIRING.
4. HOT, NEUTRAL, GND and the two IS GROUNDS should be run in the same 3/4" conduit.

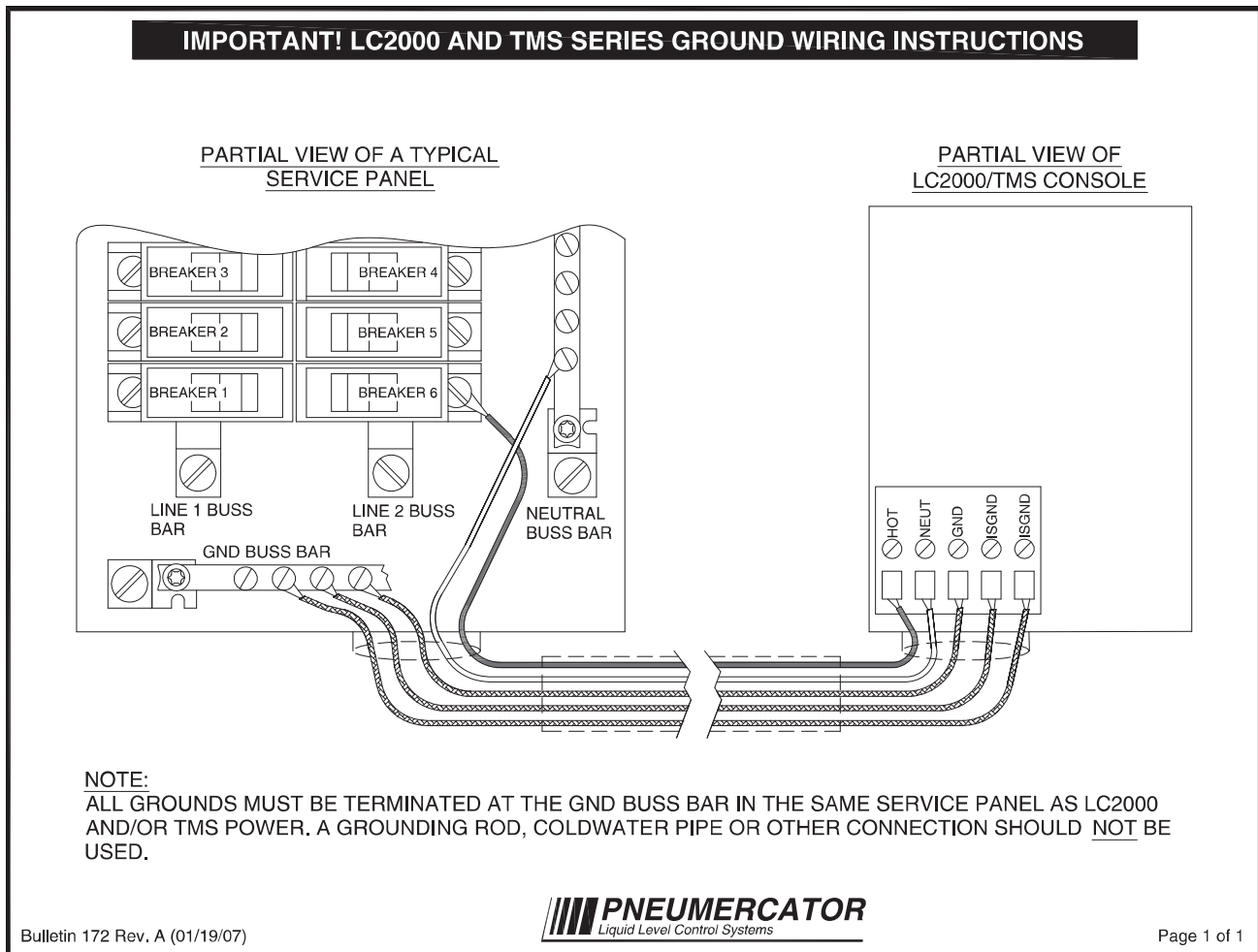
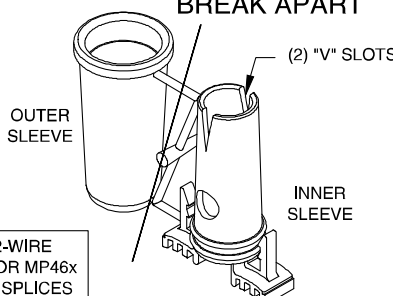
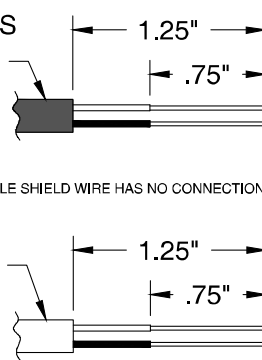
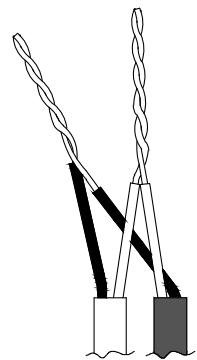
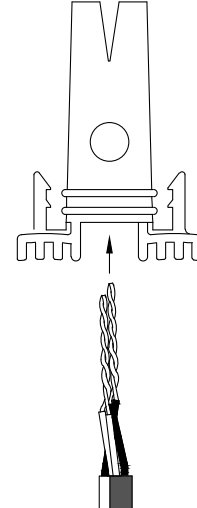
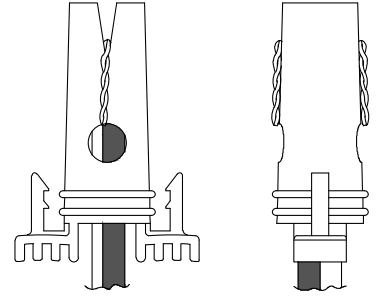
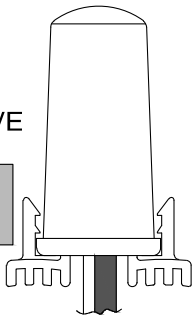

Figure 3-3 – LC2000 AC Power Wiring

3.3 SENSOR WIRING & SPLICES

WIRE SPlice AND SEAL INSTRUCTIONS - 2 CONDUCTOR PAIRS KIT 10585-2

WARNING: USE CONNECTORS ONLY FOR THEIR DESIGNATED PURPOSE. DO NOT USE FOR AC WIRING.

<p>1</p>  <p>USE TO SEAL 2-WIRE SENSOR AND/OR MP46x PROBE CABLE SPLICES</p> <p>SPLICE SEAL WIRE CONNECTOR PROVIDED BY PNEUMERCATOR</p>	<p>2 STRIP WIRES</p>  <p>* PROBE FIELD CABLE SHIELD WIRE HAS NO CONNECTION</p>
<p>3</p>  <p>TWIST WIRES</p>	<p>4</p>  <p>INSERT</p>
<p>5</p>  <p>PULL ONE TWISTED LEAD PAIR THROUGH EACH "V" AND BEND OVER</p>	<p>6</p> <p>SNAP ON OUTER SLEEVE</p> <p>DO NOT ROTATE OR TWIST OUTER SLEEVE</p> <p>DO NOT REUSE</p> 

PNEUMERCATOR
Liquid Level Control Systems

Bulletin 179 Rev. D (09/24/10) Page 1 of 1

Figure 3-6 - 2-wire sensor Splice Kit Instructions

WIRE SPLICE AND SEAL INSTRUCTIONS - 3 CONDUCTOR PAIRS KIT 10585-3

WARNING: USE CONNECTORS ONLY FOR THEIR DESIGNATED PURPOSE. DO NOT USE FOR AC WIRING.

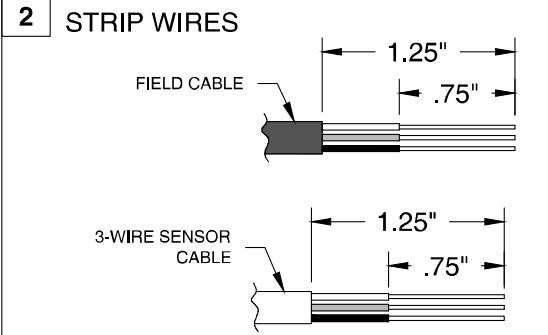
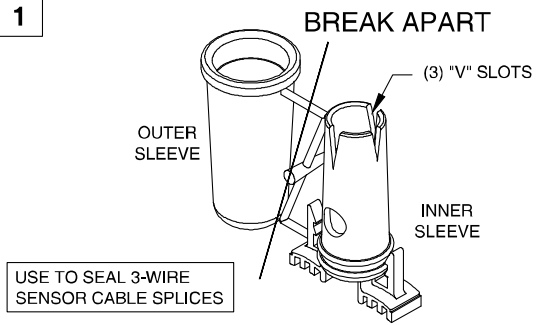

SPLICE SEAL WIRE CONNECTOR PROVIDED BY PNEUMERCATOR

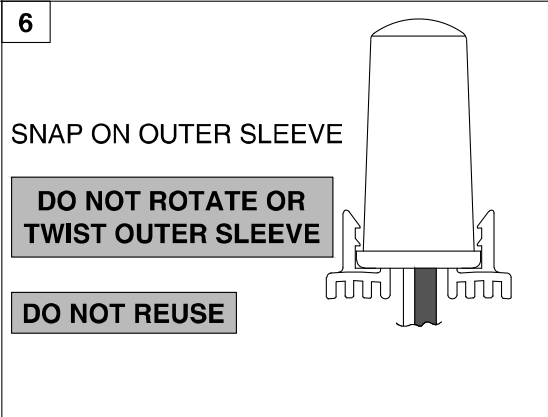
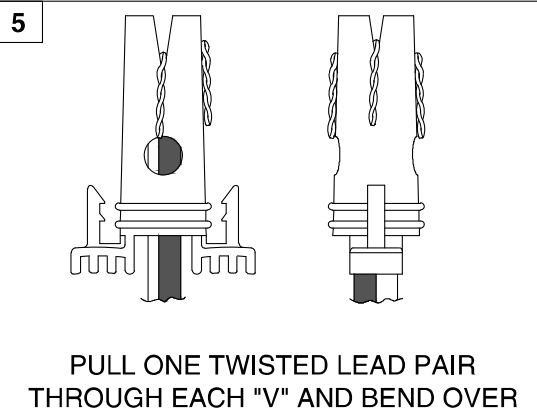
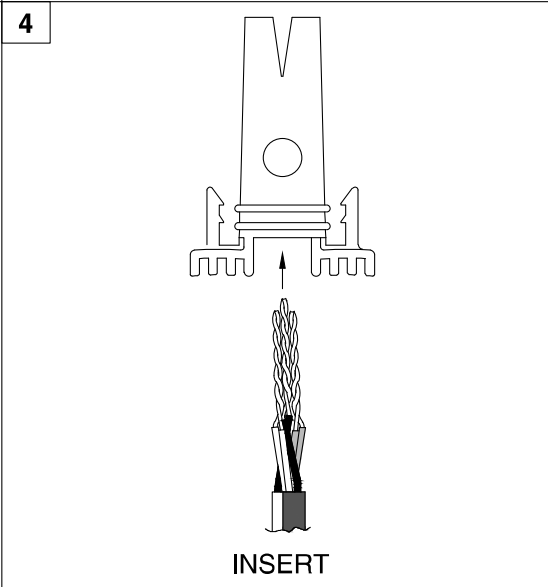
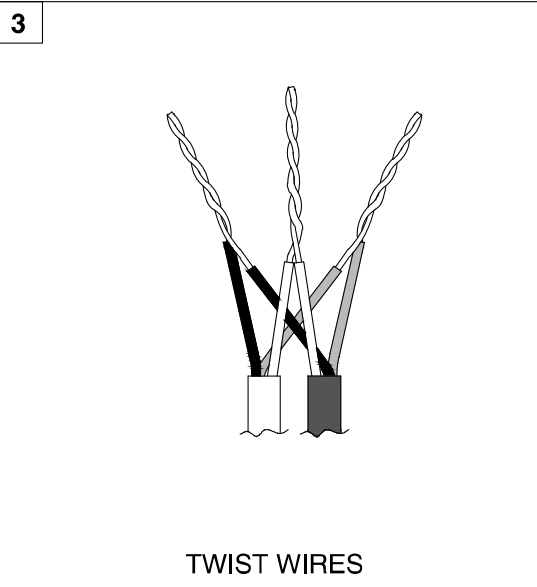
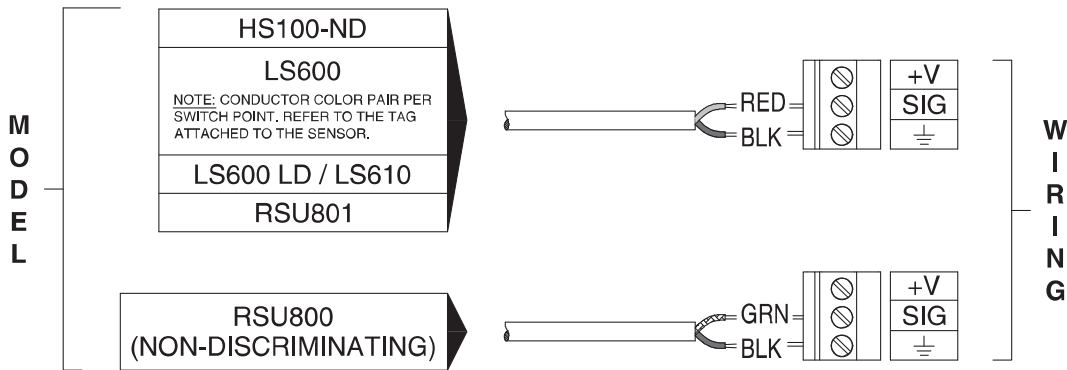

Figure 3-7 - 3-wire sensor Splice Kit Instructions

IMPORTANT! LC2000 SENSOR WIRING INSTRUCTIONS

IDENTIFY THE TYPE OF SENSOR(S) TO BE INSTALLED. WIRING MUST BE TERMINATED ON THE TERMINALS INDICATED BELOW TO ENSURE CORRECT OPERATION.

2-WIRE SENSORS



3-WIRE SENSORS

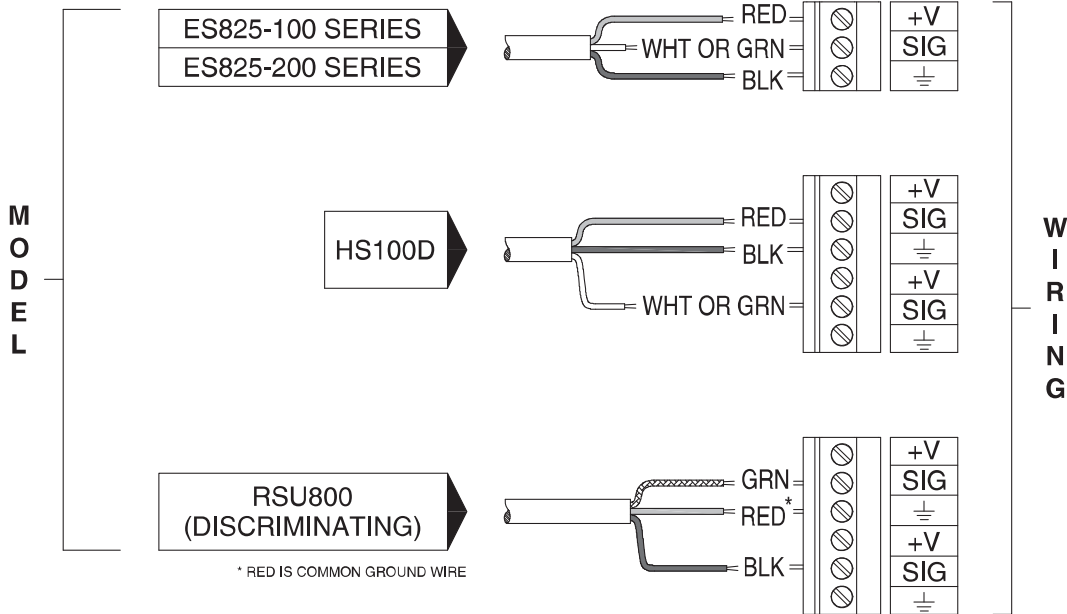

Questions? Contact Technical Support at (800) 209-7858



Figure 3-8 - LC2000 sensor wiring

3.4 PROGRAMMABLE RELAY OUTPUTS/CONTACT CLOSURE INPUTS

The LC2000 provides dry contact closure inputs and relay contact closure outputs that are user-programmable via TMSComm communications interface. Each input is programmable for relay control and alarm functions as well as remote relay acknowledgement or gating functions. Each relay output is programmable to trigger on any combination of events, including leak or point level sensor alarm, contact closure input or system error. Additionally, relays are individually programmable for failsafe mode; delayed shutoff, latching for pump up/down controls. Typical relay applications include remote annunciation, pump and siphon break/flow control valve operation, and other user-defined switch closure inputs. These relays also provide a simple and straightforward interface to most programmable logic controllers, building management systems, and similar input monitoring devices.

The standard LC2000 includes two (2) dry contact closure inputs and two (2) relay contact closure outputs as illustrated in Figure 3-9 below. Also shown is an optional 4 Input/4 Relay Output Card. An optional 8 Input/8 Relay Output Card or 16 Relay Output Card are also available.

⚠ CAUTION

Relay output and contact closure input terminals are located on the NON-INTRINSICALLY SAFE side of the console. ALL wiring to these terminals MUST enter through the designated conduit opening. Refer to FIGURE 1-3. FAILURE TO COMPLY MAY RESULT IN PERSONAL INJURY, PROPERTY LOSS AND EQUIPMENT DAMAGE.

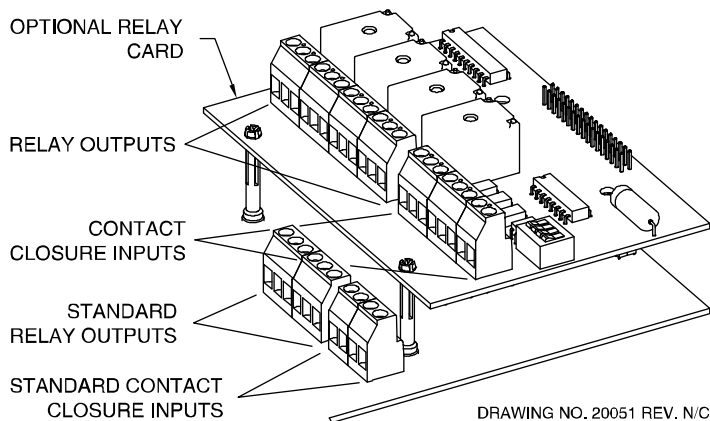

Figure 3-9 - Relay Output/Contact Closure Input Layout
(Optional 4 Relay Output/4 Contact Closure Input Expansion Card shown)

3.5 DATA COMMUNICATIONS WIRING

The non-intrinsically safe area is equipped with three (3) communications ports that are assigned as follows:

One (1) EIA RS-232 Interface to remote computer, PLC or external modem.

One (1) EIA RS-485 Interface to remotely located PNEUMERCATOR smart peripheral devices.

One (1) for use with an optional communications interface card. Available options include modem, fax/modem, Ethernet TCP/IP, ModBus RTU, LonWorks (w/gateway).

Figure 3-10 shows the locations of these connections.

⚠ CAUTION

All communication terminations are located in the NON-INTRINSICALLY SAFE side of the LC2000 console. ALL wiring to these terminals MUST enter through the designated conduit opening. Refer to FIGURE 1-3. FAILURE TO COMPLY MAY RESULT IN PERSONAL INJURY, PROPERTY LOSS AND EQUIPMENT DAMAGE.

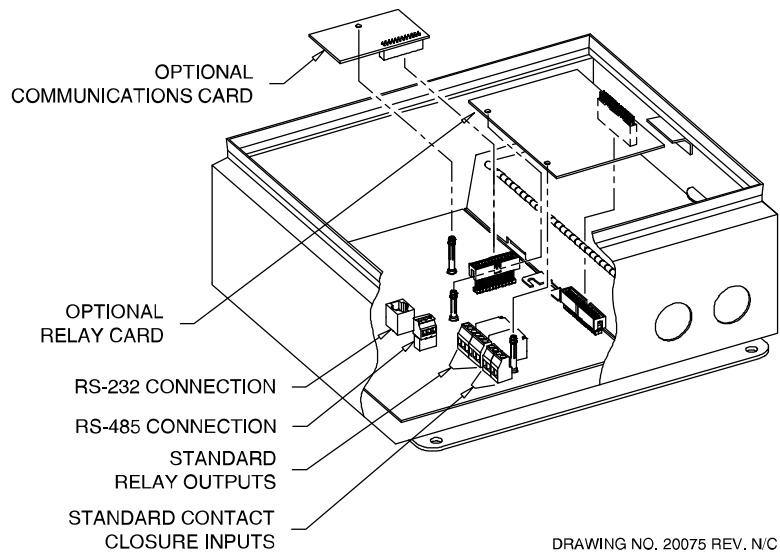
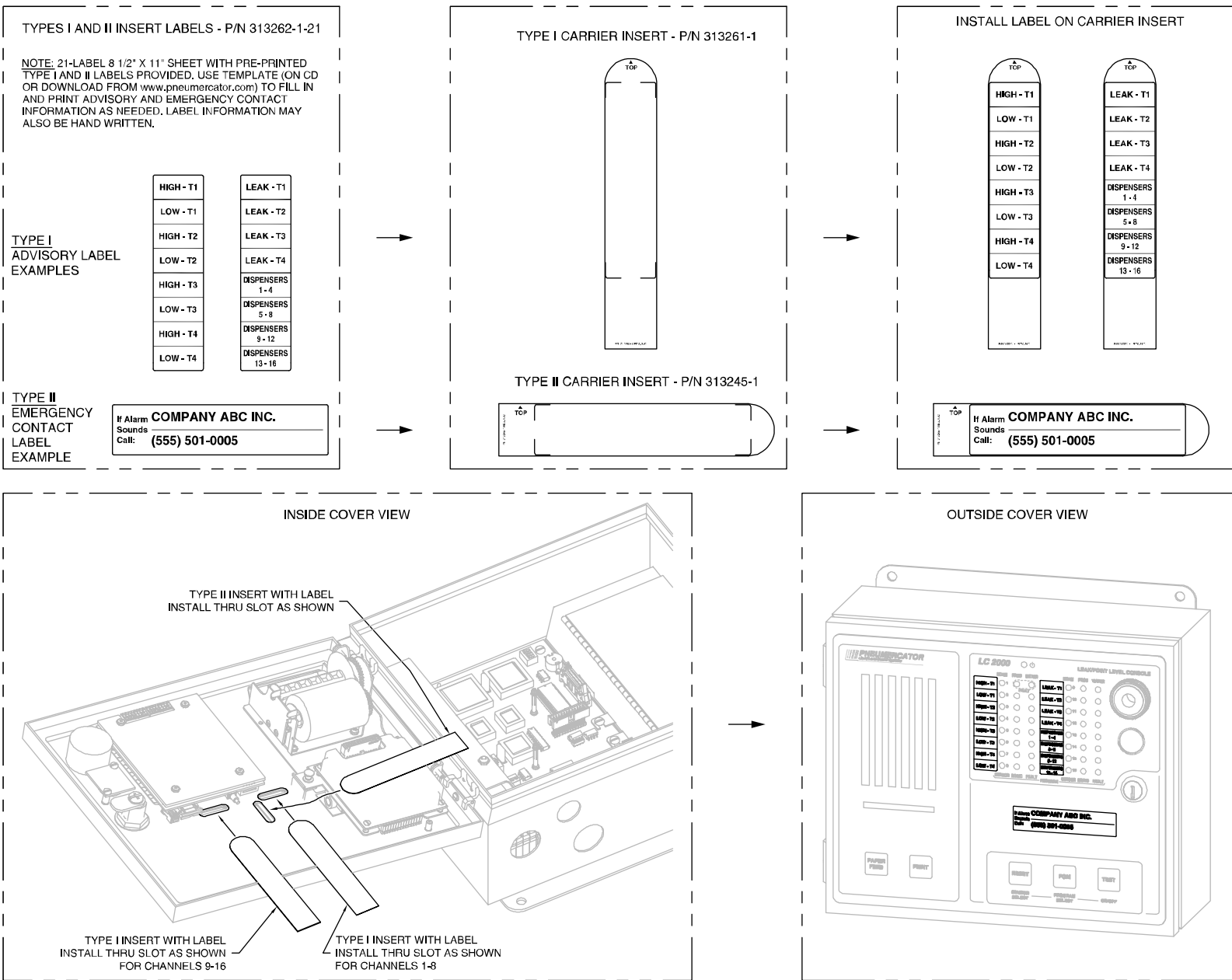

Figure 3-10 - Non-Hazardous Expansion Option Installation

3.6 LABEL INSERT CARRIER INSTRUCTIONS



DWG NO. 20074 REV. N/C

Figure 3-11 – Label Insert Carrier Instructions

3.7 INPUT/OUTPUT MAP

The INPUT/OUTPUT MAP below should be completed by the electrical installer as each sensor or contact closure input and relay control output function is wired to the LC2000 system. This will provide the equipment operator a means of identifying each field device for proper system setup programming and maintenance. The INPUT/OUTPUT MAP should be kept with the LC2000 console.

INPUT/OUTPUT MAP

INPUT #	SENSOR FUNCTION	SENSOR NAME
1		
2		
3		
4		
5		
6		
7		
8		
9		
10		
11		
12		
13		
14		
15		
16		

INPUT #	CONTACT CLOSURE(CC) INPUT FUNCTION	CC NAME
1		
2		
3		
4		
5		
6		
7		
8		
9		
10		

RELAY#	RELAY FUNCTION	RELAY NAME
1		
2		
3		
4		
5		
6		
7		
8		
9		
10		
11		
12		
13		
14		
15		
16		
17		
18		

PNEUMERCATOR LC SERIES

LIMITED WARRANTY

LC Series

Pneumercator, here and after referred to as **PCO**, warrants its **LC Series** family of products to be free of defects in material and workmanship for a period of **Twelve (12) months** from date of installation or **Fifteen (15) months** from date of invoice, whichever comes first.

During the warranty period on the **LC Series**, **PCO**, or factory third party independent representatives will repair or replace the product at the location where it is installed at no additional cost to the customer.

Packages must be inspected upon receipt for damage, missing parts, and/or manuals. **PCO** must be contacted by telephone immediately with a description of damaged or missing parts so replacements can be sent. Written details must be sent within **thirty (30) days**.

Pneumercator will not be responsible for shipping charges incurred by the customer.

Warranty repair coverage invoices will be paid if **all** the following conditions are met:

- PCO has acknowledged and authorized warranty work to be done by issuing a *Warranty Repair Number*.
- Start-up Service technician has been trained by PCO
- Warranty start-up form has been submitted to PCO
- Technician fills out and submits a PCO "Service Report"
- Parts (if any) used are returned to PCO with a proper WRGA (*Warranty Return Goods Authorization*)
- Returned parts are found to be defective.

Repair time will be paid according to PCO document "Standard Warranty Labor Charge Schedule"

If the Warranty Registration/Start up Check List has been completed and returned on file with the factory and the product is installed in accordance with the specific PCO Installation Product Manual, PCO will activate and meet warranty criteria as described above. Warranty criteria shall be voided if any product has been subjected to misuse, negligence, damage from acts of nature (lightning, wind, rain, etc.) or is in violation of the products design intent, disregard to warnings, instructions, modified or repaired by unauthorized personnel or improperly installed. Given that the third party independent contractor has installed the equipment in accordance with the specific product instruction manual, and followed all precautions, PCO will fulfill the terms stated in our warranty obligation.

Under no circumstances does the warranty provide a remedy in excess of the equipment. No other expressed or implied warranty is given by PCO. PCO shall not be liable for consequential damages or any expenses incurred by the user.

Distributed by:

 **PNEUMERCATOR**
Liquid Level Control Systems

1785 Expressway Drive North
Hauppauge NY 11788
(631) 293-8450 Fax (631) 293-8533

--