

WIRE SPLICE AND SEAL INSTRUCTIONS - 2 CONDUCTOR PAIRS KIT 10585-2L

WARNING: USE CONNECTORS ONLY FOR THEIR DESIGNATED PURPOSE. DO NOT USE FOR AC WIRING.

1

BREAK APART

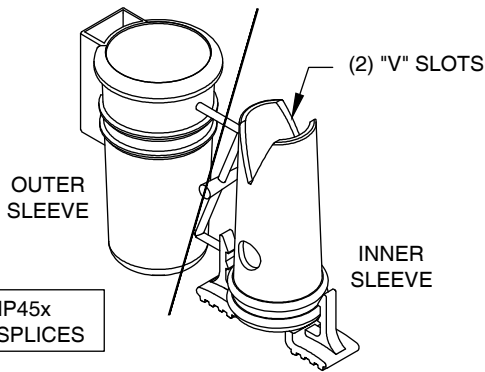

USE TO SEAL MP45x PROBE CABLE SPLICES

SPLICE SEAL WIRE CONNECTOR PROVIDED BY PNEUMERCATOR

2

STRIP WIRES

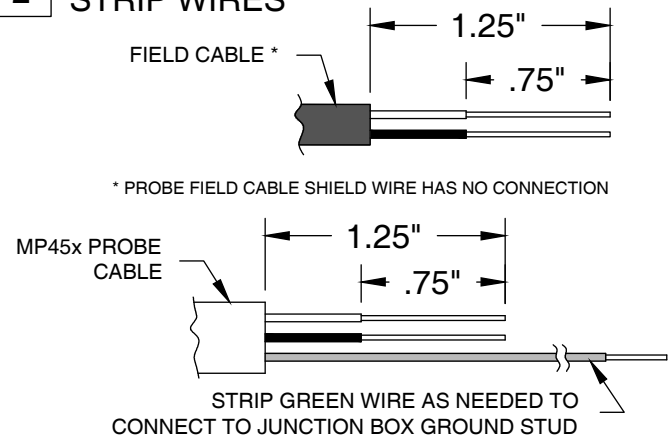

3

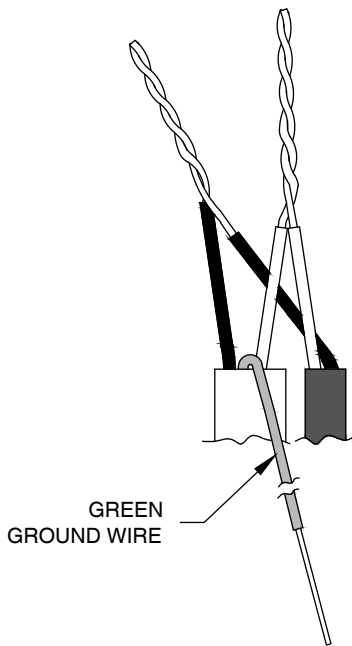

TWIST WIRES (EXCEPT FOR GND WIRE)

4

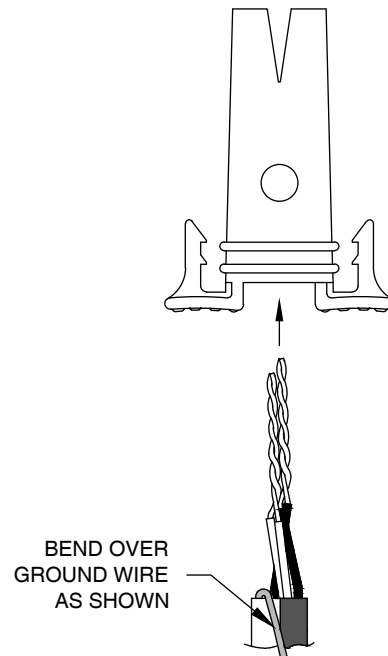

INSERT

5

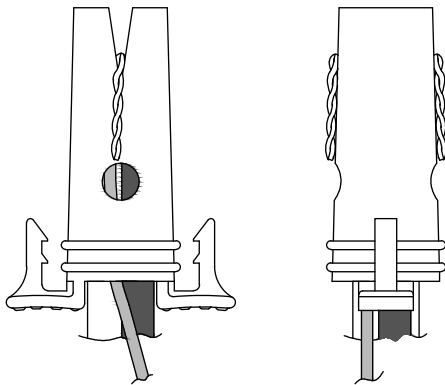

PULL ONE TWISTED LEAD PAIR THROUGH EACH "V" AND BEND OVER

6

SNAP ON OUTER SLEEVE

DO NOT ROTATE OR TWIST OUTER SLEEVE

DO NOT REUSE

CONNECT GND WIRE TO JUNCTION BOX GND STUD

